

**PIETER ADAM**<sup>TM</sup>  
FURNITURE - LIGHTING - ACCESSORIES

*Made of materials like brass, marble, glass, silk, and leather.  
A style for every person who appreciates a stylish and exclusive design.*

[pieter-adam.com](http://pieter-adam.com)

## TABLE OF CONTENTS

<b>PHILOSOPHY</b>	
Pieter Adam .....	3
<b>FURNITURE</b>	
TamTam .....	4
Collec(t)able .....	10
Circum .....	40
Baroctopus .....	51
<b>ACCESSORIES</b>	
Luxury boxes   Cocoon & Macaroon .....	53
Karma Chameleon .....	62
Volcano Candelabra .....	65
<b>LIGHTING</b>	
Sea Treasure .....	68
Curva Culta .....	75
Melting Paradise .....	85
CarniForest .....	91
Worntorch .....	97
Mysterious Bamboo .....	100
Melting Paris .....	106
Twiggy .....	117
Rosedale .....	132
Le Soleil .....	141
Organic Atomic .....	144
Pavement .....	155
Bronx .....	158
Melting Amsterdam .....	167
Melting Fez .....	174
Melting Florence .....	176
<b>MATERIAL LIBRARY</b>	
Intro material library .....	181
Straw .....	182
Leather .....	183
Miscellaneous .....	184
<b>INDEX</b> .....	186
<b>CONTACT INFORMATION</b> .....	191



## PHILOSOPHY

Drawing from years of experience in exclusive lighting, Pieter Adam started his line of lighting as an alternative to the volatile, temporary and trendy mass production items available everywhere. His main focus was on quality and exclusivity with durability, craftsmanship and expertise being high on his priority list.

With a clean slate and full of ideas we began the Pieter Adam Collection with the key words contemporary, exclusive and stylish serving as the main design focus. Every detail and every piece was carefully thought out leaving nothing to chance.

Quality through expertise. Our many years of experience with bronze founders, glass blowers, granite refiners, and silk weavers enables our highly skilled craftsmen to make special limited edition pieces. As a result, we are able to meet special needs and requests, such as complete custom designed lighting plans for special projects.

Perfection is paramount in the Pieter Adam collection. From the silk chords to the metal housing for each fitting, a Pieter Adam piece is assembled with scrutiny and passion. A showpiece in your interior radiating international splendour.





## TAMTAM

As a certified furnituremaker and designer, Pieter has a lot of passion for furniture. In his search for new and eco-conscious materials, Pieter found lots of inspiration in the opportunities straw marquetry offers. Pieter let his creativity run wild and created a furniture line with this unique material.

This series of luxurious tables are made with high quality materials, such as brass, leather and straw marquetry. Pieter combined modern- with geometrical shapes, which makes this collection easily integrates in its environment while leaving a great impression.

Straw marquetry is a very unique and specific craft which is a labor-intensive process. Each straw will be cut by hand before it get soak in cold and hot water. Afterwards the straws are ironed and coloured in a bath. By ironing it, the straws get that colour gradient which makes these tables absolutely stunning!



# TAMTAM

Item nr. FPA 300  
Model TamTam table large  
Material Casted brass, straw marquetry, leather  
Dimensions Ø120 x H37 cm  
Finishes Straw: Forest Brown / **Emerald Green** / Worn Silver\*

*\*For images of the other finishes visit our website >*

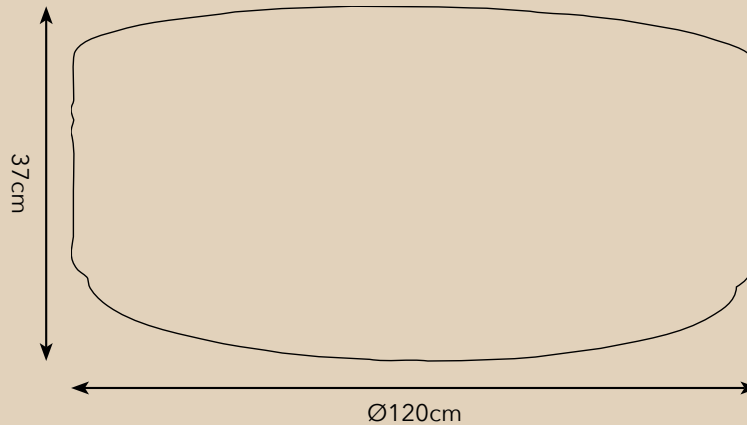

[Straw library >](#)  
[Leather library >](#)





# TAMTAM

- Item nr. FPA 301
- Model TamTam table medium
- Material Casted brass, straw marquetry, leather
- Dimensions Ø90 x H45cm
- Finishes Straw: **Forest Brown** / Emerald Green / Worn Silver\*

\*For images of the other finishes visit our website >

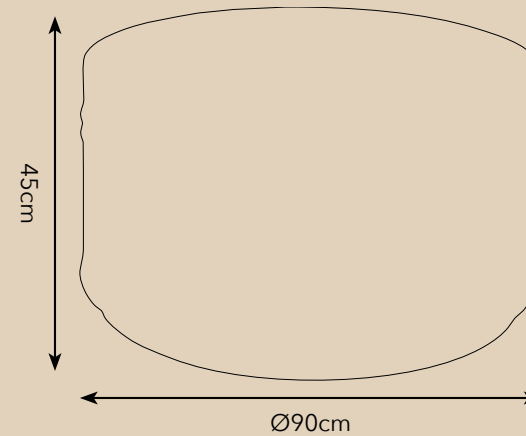

[Straw library >](#)  
[Leather library >](#)







# TAMTAM

- Item nr. FPA 302
- Model TamTam table small
- Material Casted brass, straw marquetry, leather
- Dimensions Ø60 x H55 cm
- Finishes Straw: Forest Brown / Emerald Green / Worn Silver\*

\*For images of the other finishes visit our [website](#) >

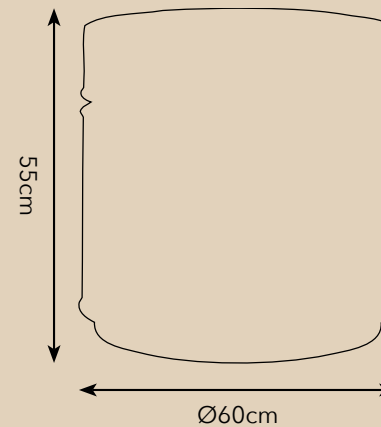

[Straw library >](#)  
[Leather library >](#)



## COLLEC(T)ABLE

Pieter Adam's Collec(t)able series comprehends a sophisticated design that exudes elegance and style, this series of tables are perfectly suitable for any interior. These tables can perfectly be combined with Pieter Adam's lighting series, which will create a stylish and cohesive interior design!

This line of furniture pieces contains both rectangular and round-shaped tables and are finished in antique silver or antique gold. The table tops are made from eco-conscious materials, like bamboo, selenite, straw marquetry and feature an geometric pattern.

An unique look can easily be created by mixing different kinds of tables together with different kinds of table tops. The possibilities are endless, allowing you to unleash your creativity and design your own unique table!



# COLLEC(T)ABLE

**Item nr.** FPA 501  
**Model** Collec(t)able rectangular coffee table large  
**Material** Iron, straw, glass  
**Dimensions** 130 x 90 x H35 cm  
**Finishes** Antique silver, antique gold\*

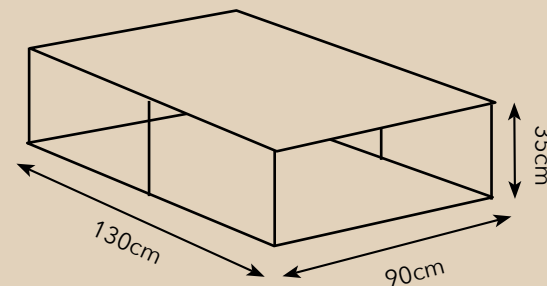

[Straw library >](#)

\*Other patterns and materials for table tops on request. Visit our website >



# COLLEC(T)ABLE

**Item nr.** FPA 502  
**Model** Collec(t)able rectangular coffee table small  
**Material** Iron, straw, glass  
**Dimensions** 90x 60 x H25 cm  
**Finishes** Antique silver, antique gold\*

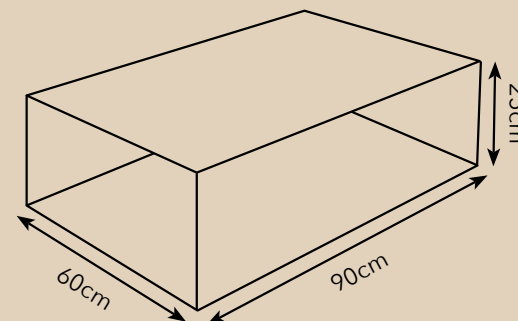

[Straw library >](#)

\*Other patterns and materials for table tops on request. Visit our website >



A round, multi-tiered table with a radial wood grain pattern on the top surface and thin metal legs.

A round, multi-tiered table with a radial wood grain pattern on the top surface and thin metal legs, positioned in the foreground.

A round, multi-tiered table with a radial wood grain pattern on the top surface and thin metal legs, positioned on the right side.

A lamp with a textured, cylindrical shade and a glass base, resting on the leftmost table.

A lamp with a textured, cylindrical shade and a glass base, positioned in the center.

A lamp with a textured, cylindrical shade and a glass base, resting on a dark rectangular pedestal on the right.

A glass bowl containing several small, round, light-colored fruits, possibly lemons or grapefruit segments.

A wooden lidded container with a circular top, resting on the middle table.

A wooden lidded container with a circular top, resting on the rightmost table.

A potted plant with green leaves and moss, sitting behind the central lamp.



# COLLEC(T)ABLE

Item nr. FPA 503  
Model Collec(t)able end table  
Material Iron, straw, glass  
Dimensions 70 x 70 x H45 cm  
Finishes Antique silver, antique gold\*

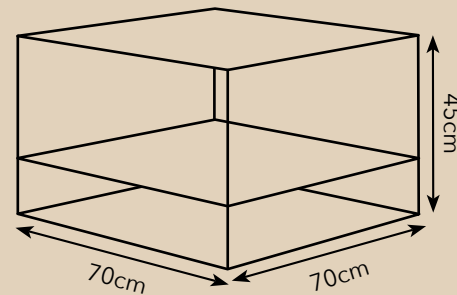

[Straw library >](#)

\*Other patterns and materials for table tops on request. Visit our website >



# COLLEC(T)ABLE

**Item nr.** FPA 504  
**Model** Collec(t)able end table with tray  
**Material** Iron, straw, glass  
**Dimensions** 70 x 70 x H45 cm  
**Finishes** Antique silver, antique gold\*

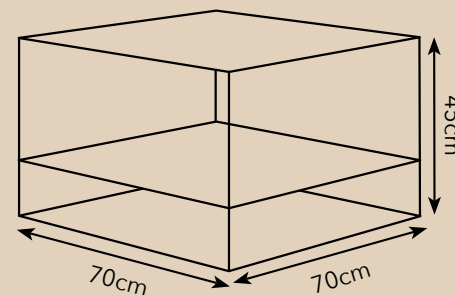

[Straw library >](#)

\*Other patterns and materials for table tops on request. Visit our website >



WHAT YOU SEE IS WHAT YOU GET

STEVE ADAM COLLETTIABLE

What you see is what you get  
A collection of jewelry  
that is as beautiful as the woman  
who wears it.



Item nr. FPA 506  
Model Collec(t)able high square pillar  
Material Iron, straw, glass  
Dimensions 30 x 30 x H120 cm  
Finishes Antique silver, antique gold\*

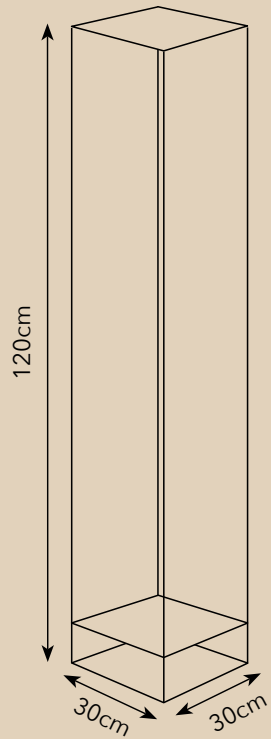

[Straw library >](#)

\*Other patterns and materials for table tops on request.  
[Visit our website >](#)



Item nr. FPA 507  
Model Collec(t)able sofa table  
Material Iron, straw, glass  
Dimensions 40 x 55 x H70cm  
Finishes Antique silver, antique gold\*

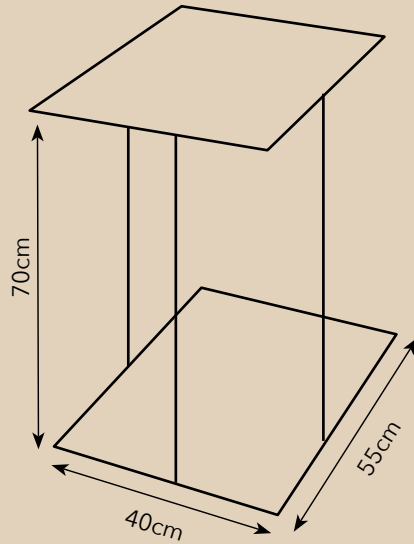

[Straw library >](#)

\*Other patterns and materials for table tops on request.  
[Visit our website >](#)



Item nr.	FPA 508
Model	Collec(t)able sofa table with usb port
Material	Iron, straw, glass
Dimensions	40 x 55 x H70cm
Finishes	Antique silver, antique gold*

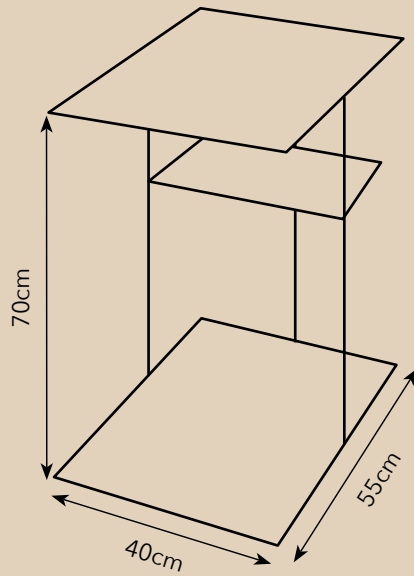

[Straw library >](#)

\*Other patterns and materials for table tops on request.  
[Visit our website >](#)





Item nr.	FPA 509
Model	Collec(t)able round side table
Material	Iron, straw, selenite
Dimensions	Ø60 x H60 cm
Finishes	Antique silver, antique gold*

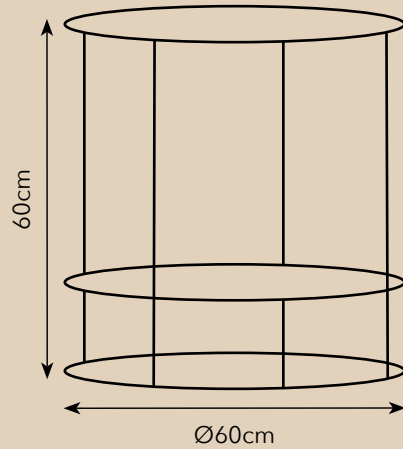

[Straw library >](#)

[Selenite >](#)

\*Other patterns and materials for table tops on request.  
[Visit our website >](#)





# COLLEC(T)ABLE

Item nr. FPA 510  
Model Collec(t)able round coffee table large  
Material Iron, bamboo  
Dimensions Ø80 x H40 cm  
Finishes Antique silver, antique gold, bamboo: Sunshine Brown\*

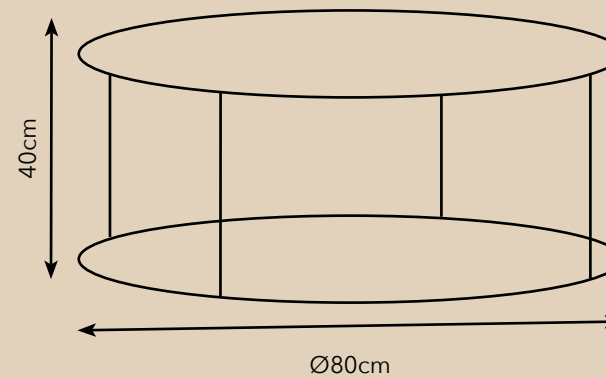

[Bamboo library >](#)

\*Other patterns and materials for table tops on request. Visit our [website >](#)



# COLLEC(T)ABLE

**Item nr.** FPA 511  
**Model** Collec(t)able round coffee table large  
**Material** Iron, straw, glass  
**Dimensions** Ø100 x H30 cm  
**Finishes** Antique silver, antique gold\*

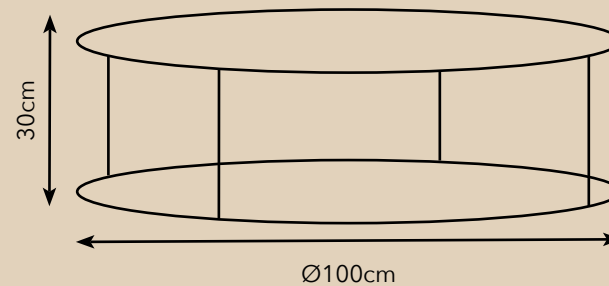

[Straw library >](#)

\*Other patterns and materials for table tops on request. Visit our [website >](#)





Item nr. FPA 512  
Model Collec(t)able high round pillar  
Material Iron, bamboo, straw  
Dimensions Ø35 x H120cm  
Finishes Antique silver, antique gold, bamboo:  
Sunshine Brown\*

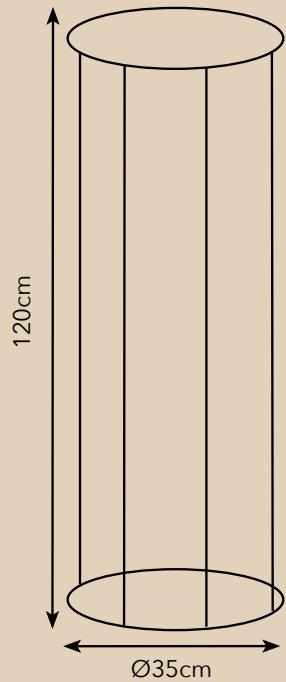

[Straw library >](#)

[Bamboo >](#)

\*Other patterns and materials for table tops on request.

[Visit our website >](#)



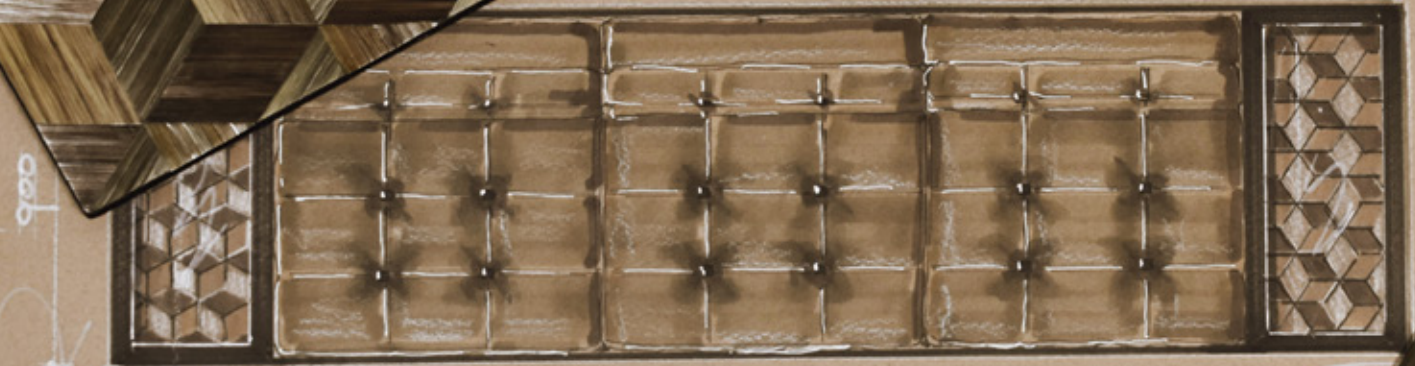

900

Top view

STUDIO  
PIETER ADAM  
ALL RIGHTS RESERVED  
WWW.PIETER-ADAM.COM



PIETER ADAM™  
COLLEC[T]ABLE SOFA  
All rights reserved  
www.pieter-adam.com

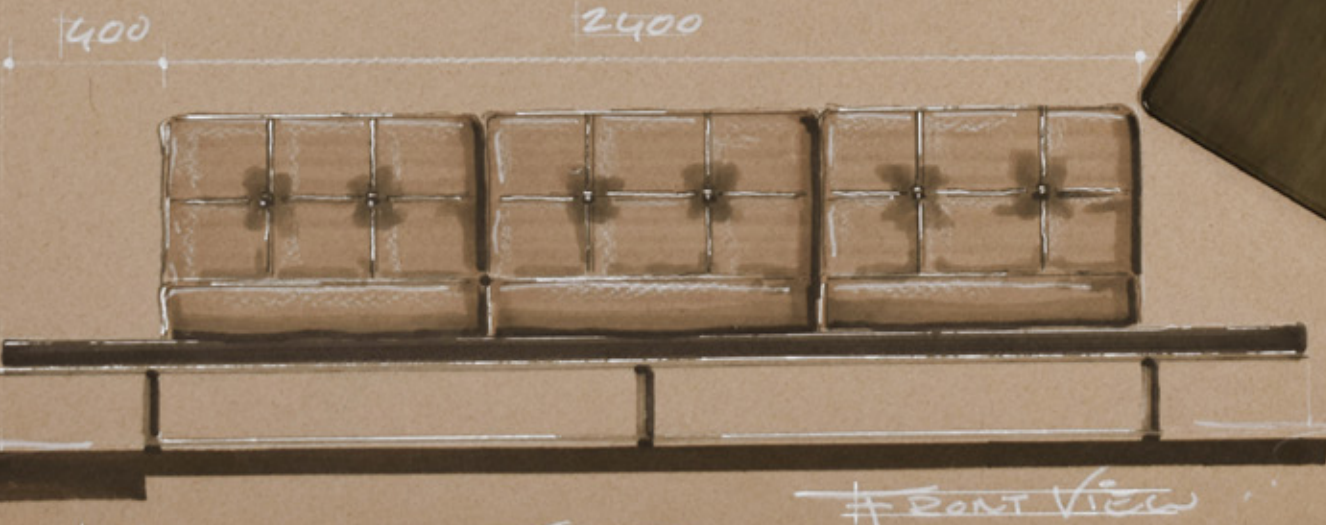

650

400

2400

230

Front view



400 30120



30120

Side view

COLLECTABLE SOFA  
MODULAR SOFA  
SEPT 2023 BY PIETER ADAM

FPA 530



## COLLEC(T)ABLE

**Item nr.** FPA 530  
**Model** Collec(t)able sofa shelf service  
**Material** Iron, straw, glas, corduroy  
**Dimensions** 320 x 90 x H83 cm  
**Finishes** Antique silver, antique gold\*

\*Other finishes on request. For images visit our [website](#) >

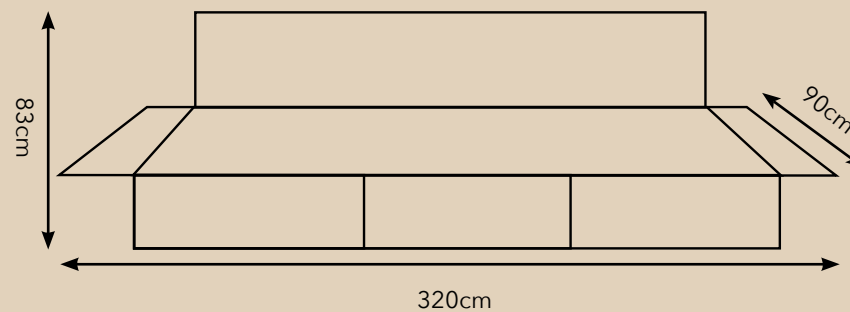

[Straw library >](#)





## COLLEC(T)ABLE

**Item nr.** FPA 531  
**Model** Collec(t)able chair shelf service right  
**Material** Iron, straw, glas, leather  
**Dimensions** 120 x 85 x H85 cm  
**Finishes** Antique silver, antique gold\*

\*Other finishes on request. For images visit our [website](#) >

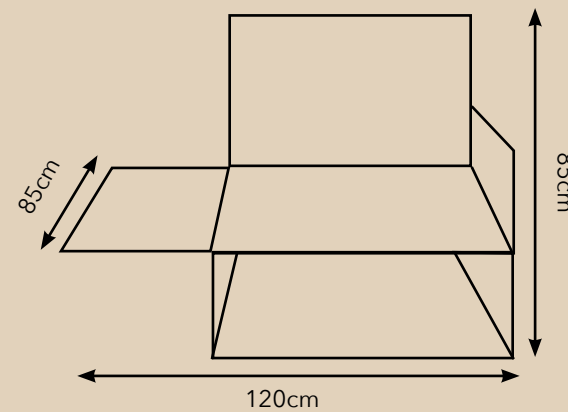

[Straw library >](#)  
[Leather library >](#)





## COLLEC(T)ABLE

**Item nr.** FPA 532  
**Model** Collec(t)able chair shelf service left  
**Material** Iron, straw, glas, leather  
**Dimensions** 120 x 85 x H85 cm  
**Finishes** Antique silver, antique gold\*

\*Other finishes on request. For images visit our [website](#) >

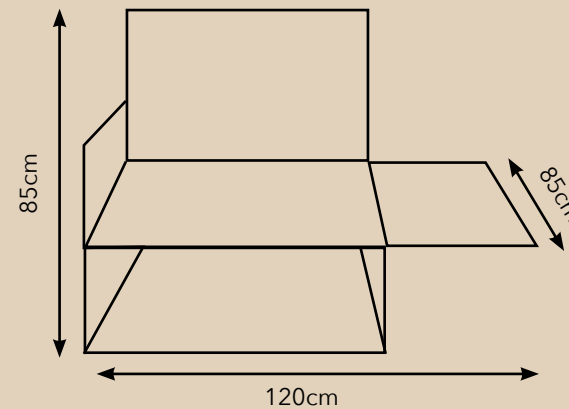

[Straw library >](#)  
[Leather library >](#)







# COLLEC(T)ABLE

Item nr. FPA 534  
Model Collec(t)able chaise longue  
Material Iron, straw, corduroy  
Dimensions 180 x 68 x H60 cm  
Finishes Antique silver, antique gold, rose\*

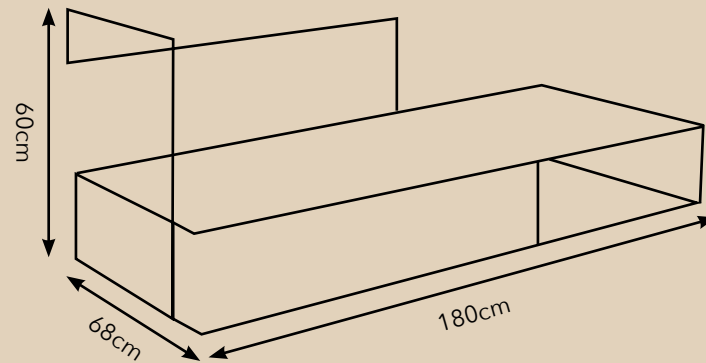

Straw library >  
Leather library >

\*Other finishes on request. For images visit our [website](#) >



Item nr. FPA 533  
Model Collec(t)able sofa  
Material Iron, straw, leather  
Dimensions 257,5 x 85 x H85 cm  
Finishes Antique silver, antique gold

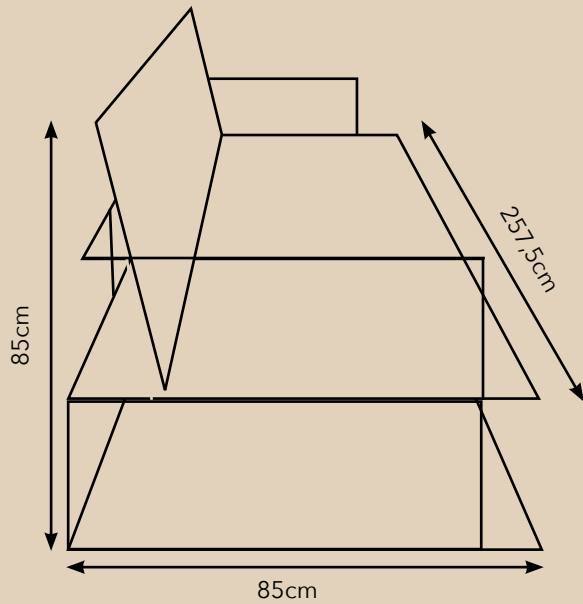

[Straw library >](#)

[Leather library >](#)

*\*Other finishes on request. For images visit our website >*





# COLLEC(T)ABLE

**Item nr.** FPA 536  
**Model** Collec(t)able arm chair left  
**Material** Iron, straw, leather  
**Dimensions** 68 x 68 x H60 cm  
**Finishes** Antique silver, antique gold\*

\*Other finishes on request. For images visit our [website](#) >

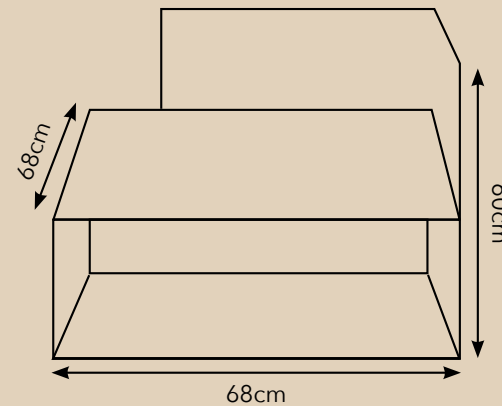

[Straw library >](#)  
[Leather library >](#)





## COLLEC(T)ABLE

Item nr. FPA 538  
Model Collec(t)able hocker  
Material Iron, straw, corduroy  
Dimensions 85 x 65 x H40 cm  
Finishes Antique silver, antique gold\*

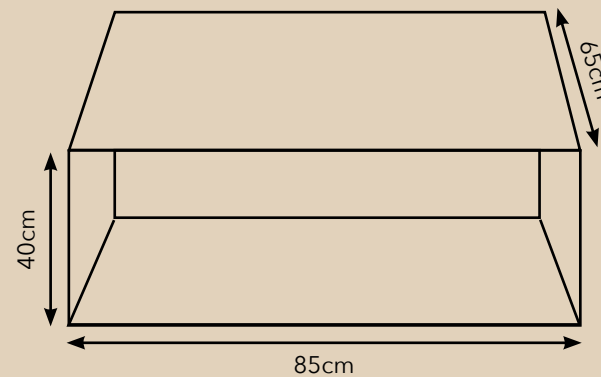

Straw library >  
Leather library >

\*Other finishes on request. For images visit our [website](#) >



# COLLEC(T)ABLE

Item nr. FPA 538  
Model Collec(t)able hocker  
Material Iron, straw, leather  
Dimensions 85 x 65 x H40 cm  
Finishes Antique silver, antique gold\*

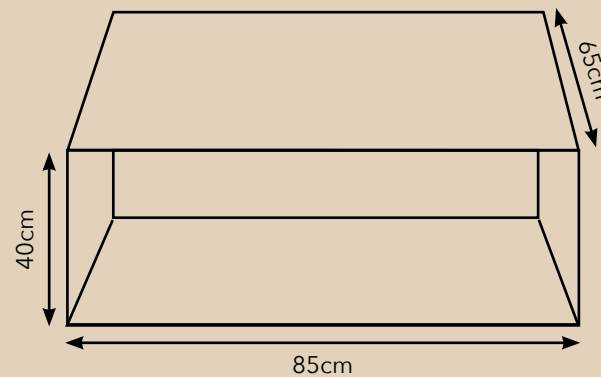

[Straw library >](#)  
[Leather library >](#)

\*Other finishes on request. For images visit our [website >](#)



## CIRCUM

Pieter regularly retreats to his design studio to create new lighting and furniture pieces. With lots of experience and inspiration, he created the Circum series. This series is in perfect harmony with the TamTam and Collec(t)able series.

Characteristic for this series are the brass details, which are visible in each design. The dressers and sofa are beautifully finished with high quality leather on the inside, and luxury eco-conscious materials on the outside.

All pieces within this series can be made with lots of different materials and finishes in various colours. With our wide range of materials and finishes, this series is perfect for customization.



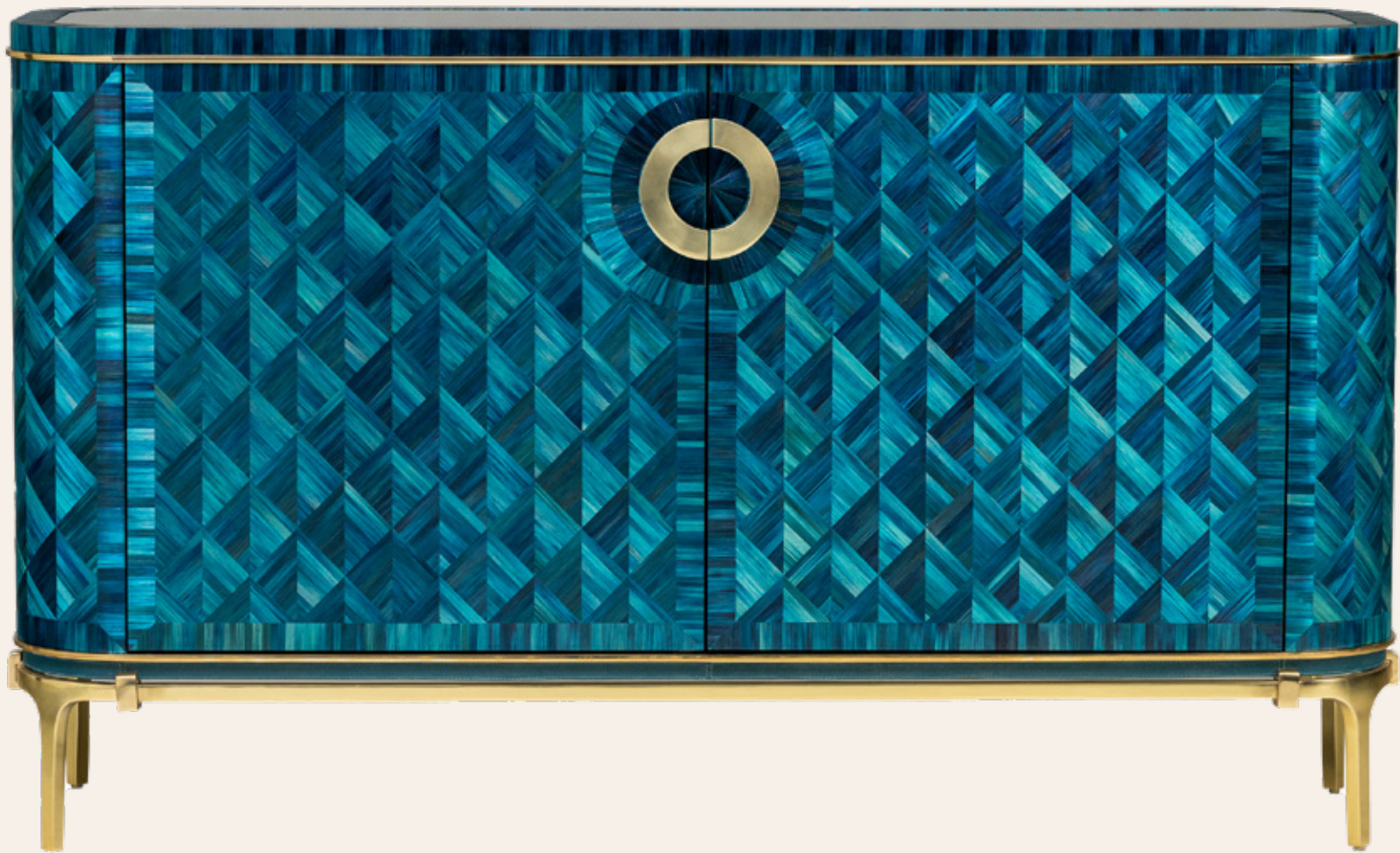

# CIRCUM

**Item nr.** FPA 400  
**Model** Circum dresser  
**Material** Casted brass, glass, straw, leather  
**Dimensions** 150 x 45 x H90 cm  
**Finishes** Finishes straw, veneer on request\*

\*Other finishes and patterns on request. Visit our [website](#) >



*Straw library >*  
*Leather library >*  
*Veneer library >*  
*Parchment library >*

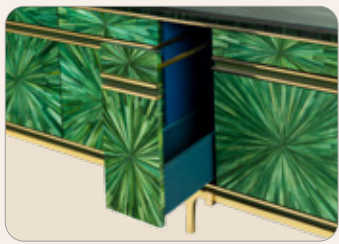

# CIRCUM

Item nr. FPA 401  
 Model Circum lowboard  
 Material Casted brass, glass, straw, leather  
 Dimensions 206 x 55 x H65 cm  
 Finishes Finishes straw, veneer on request\*

\*Other finishes and patterns on request. Visit our [website](#) >

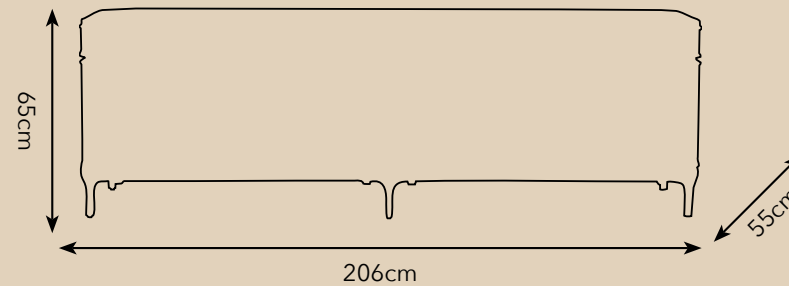

- [Straw library >](#)
- [Leather library >](#)
- [Veneer library >](#)
- [Parchment library >](#)



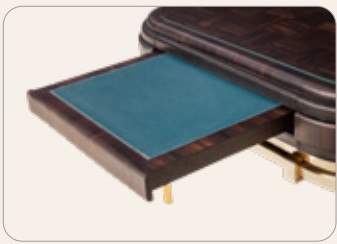

# CIRCUM

**Item nr.** FPA 402  
**Model** Circum end table  
**Material** Casted brass, glass, leather, Ebony Macassar  
**Dimensions** 80 x 80 x H42,5 cm  
**Finishes** Finishes straw, veneer on request\*

\*Other finishes and patterns on request. Visit our [website](#) >

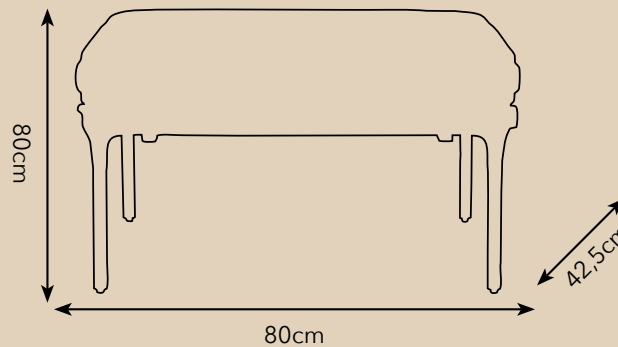

*Straw library >*  
*Leather library >*  
*Veneer library >*





# CIRCUM

**Item nr.** FPA 404  
**Model** Circum coffee table  
**Material** Casted brass, glass, leather, Ebony Macassar  
**Dimensions** 150 x 80 x H42,5 cm  
**Finishes** Finishes straw, veneer on request\*

\*Other finishes and patterns on request. Visit our [website](#) >



[Straw library >](#)  
[Leather library >](#)  
[Veneer library >](#)





# CIRCUM

**Item nr.** FPA 405  
**Model** Circum sideboard  
**Material** Casted brass, glass, leather, Ebony Macassar  
**Dimensions** 206 x 46 x H66,5 cm  
**Finishes** Finishes straw, veneer on request\*

\*Other finishes and patterns on request. Visit our [website](#) >

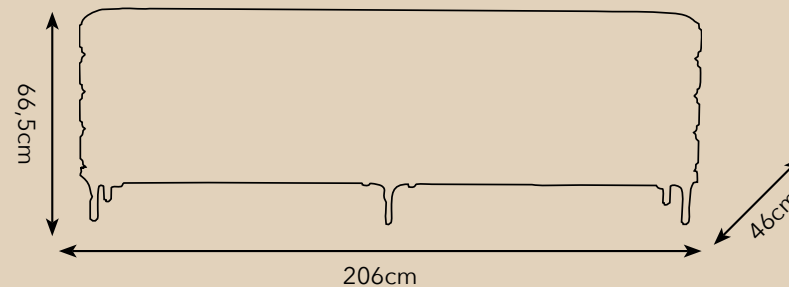

[Straw library >](#)  
[Leather library >](#)  
[Veneer library >](#)







# CIRCUM

**Item nr.** FPA 406  
**Model** Circum sofa  
**Material** Casted brass, straw, leather  
**Dimensions** 240 x 80 x H85 cm  
**Finishes** Finishes straw, veneer on request\*

\*Other finishes and patterns on request. Visit our [website](#) >

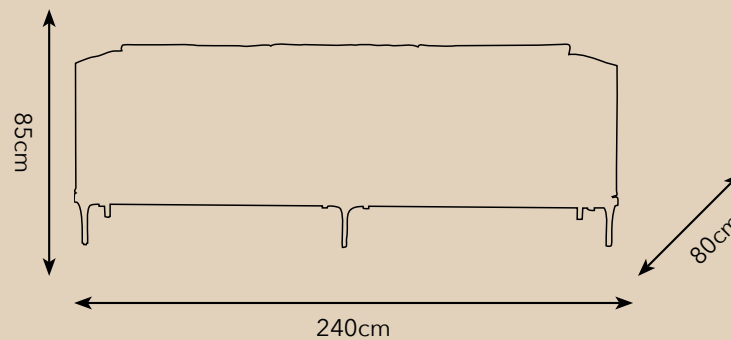

- [Straw library >](#)
- [Leather library >](#)
- [Veneer library >](#)
- [Parchment library >](#)



## BAROCTOPUS

The world underneath the surface is an amazing and intriguing one, housing some of the most beautiful and curious creatures. Taken from the sea world, this piece of both art and furniture combines a highly decorative aesthetic with functional purpose. The curly tentacles of the octopus even remind us of the curved shapes of baroque. The suckers on the underside of the tentacles show the artist's keen eye for detail that is carried out through the full bottom of the sculpture.



# BAROCTOPUS

**Item nr.** FPA 150  
**Materials** Casted Brass, glass (*Glass plate size on request*)  
**Dimensions** ø100 x H52cm (*incl. 10 mm tempered glass plate*)  
**Finishes** Natural brass (*Other finishes on request*)

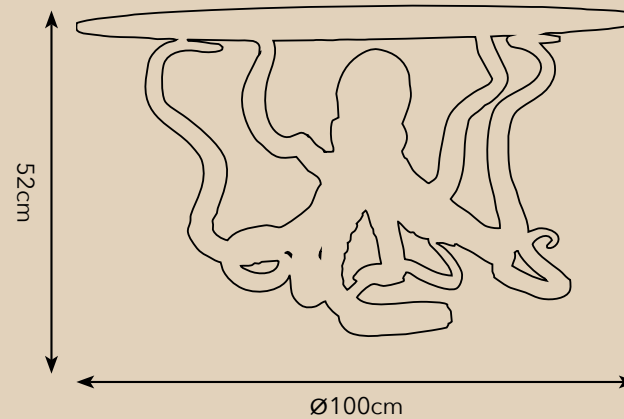



## LUXURY BOXES COCOON & MACAROOON

Pieter has expanded his collection of accessories with two kinds of luxury boxes, both are truly remarkable. The luxury boxes, called Cocoon and Macaroon, are crafted from high-quality materials, such as casted brass, leather, straw marquetry. When opening the box you will be amazed by the black and white geometric pattern made of polystone.

These exquisite boxes are the perfect accessory to add a touch of luxury, elegance and sophistication to any space.





## COCOON LUXURY BOX

**Item nr.** FPA 620  
**Model** Cocoon luxury box low  
**Material** Casted brass, straw, parchment, polystone  
**Dimensions** Ø36 x H18 cm  
**Finishes** Chocolate Brown, Emerald Green, Jack Black\*

\*Other finishes on request. Visit our website >

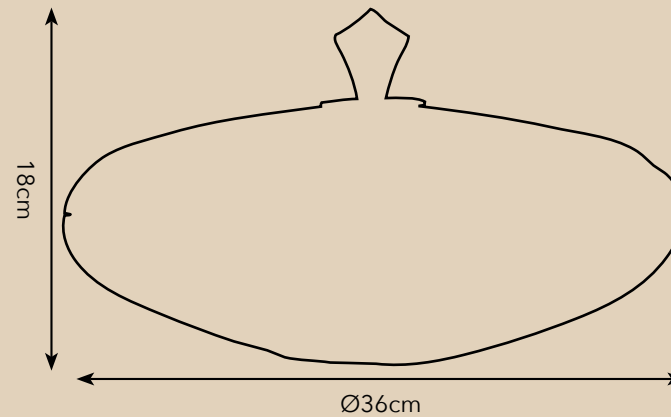

[Straw library >](#)  
[Parchment library >](#)







## COCOON LUXURY BOX

**Item nr.** FPA 621  
**Model** Cocoon luxury box high  
**Material** Casted brass, straw, parchment, polystone  
**Dimensions** Ø36 x H29 cm  
**Finishes** Chocolate Brown, Emerald Green, Jack Black\*

*\*For images of the other finishes visit our website >*

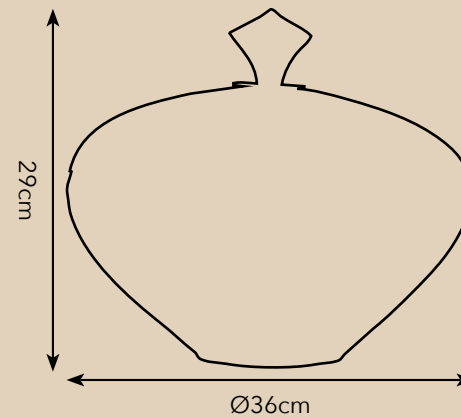

*Straw library >*  
*Parchment library >*



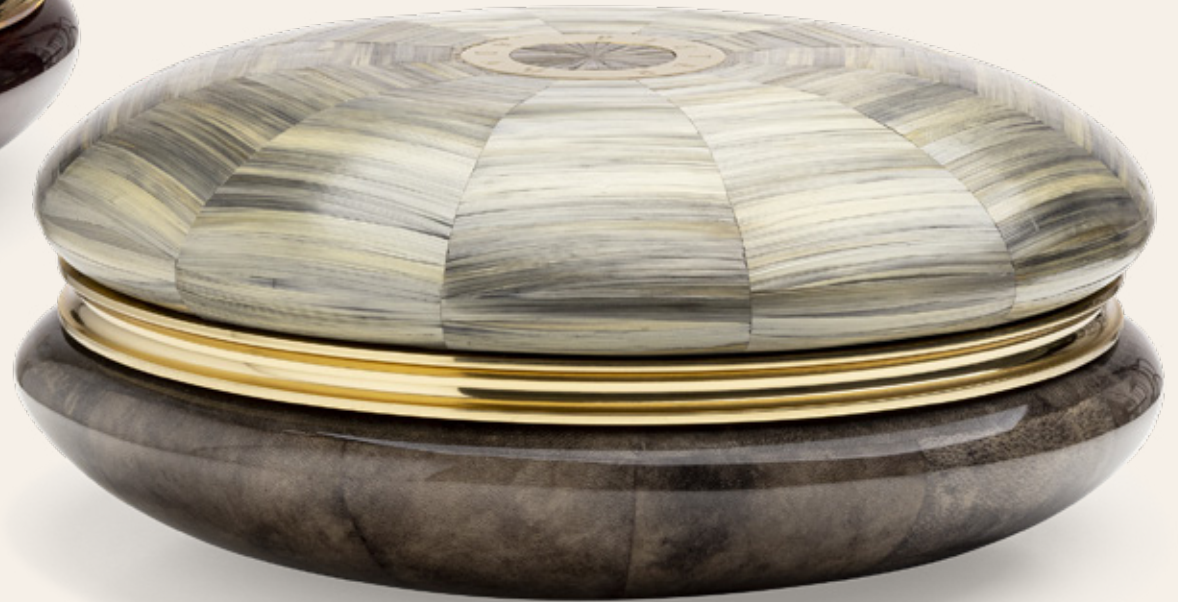

# MACAROON LUXURY BOX

**Item nr.** FPA 610  
**Model** Macaroon luxury box large  
**Material** Casted brass, straw, parchment, polystone  
**Dimensions** Ø35 x H14 cm  
**Finishes** Chocolate Brown, Emerald Green, Worn Silver\*

\*For images of the other finishes visit our [website](#) >

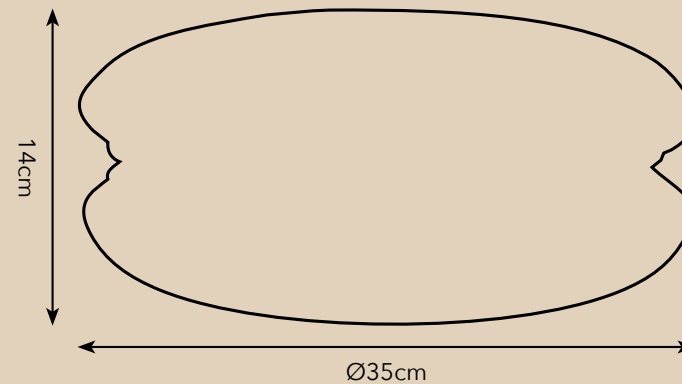

[Straw library >](#)  
[Parchment library >](#)



## MACAROON LUXURY BOX

- Item nr.** FPA 611
- Model** Macaroon luxury box small
- Material** Casted brass, straw, parchment, polystone
- Dimensions** Ø25 x H14 cm
- Finishes** Chocolate Brown, Emerald Green, Worn Silver\*

\*For images of the other finishes visit our website >

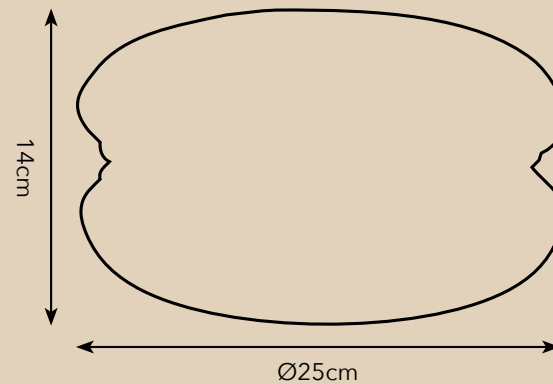

[Straw library >](#)  
[Parchment library >](#)





## KARMA CHAMELEON

Every once in a while, Pieter retreats to his happy place; his atelier. For him, as an artist, there is no greater joy than to create something from a large piece of wax using just his bare hands. This sculpture succeeds in being true to nature while also showing the artist's characteristic hand. With its colour-changing skin, specialised eyes and long tongue, the chameleon is quite the distinguished outsider. A creature that is unique in both the animal world as well as the world of interior!



# KARMA CHAMELEON

**Item nr.** PA 602  
**Material** Casted Brass  
**Dimensions** W70 x D21 x H29 cm  
**Finishes** Natural brass, Dutch silver\*

*\*For images of the other finishes visit our [website](#) >*

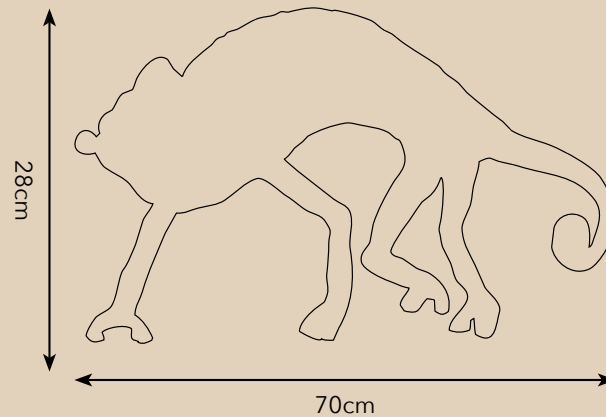







## VOLCANO CANDELABRA

What a fascinating design this large candelabra! The designer took an edgy take on the classical shapes of candleholders, connecting a timeless design with a raw texture and yet lush appearance. This contrast is exactly what makes this design piece so interesting. The rough surface with its natural, organic irregularity suggests the brass was allowed to find its own way, like lava does. The actual form remains symmetrical though and the natural brass or Dutch silver finish provides that lustrous and chic look. The large number of candles will bring the warmth of the brass and the intimate flames to any interior environment. The effect is pure magic.

Item nr. PA 603  
Model Volcano Candelabra  
Material Casted brass  
Dimensions 42 x 42 x H52 cm  
Finishes Dutch silver, natural brass\*

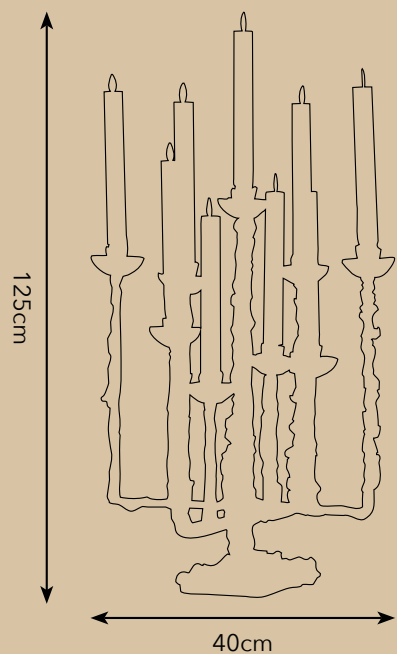

\*For images of the other finishes visit our [website](#) >



PIETER ADAM





## SEA TREASURE

The Sea Treasure collection by Pieter Adam captures the mystery and allure of the deep sea, bringing its timeless beauty into your home.

This exclusive series of lighting is crafted from casted brass and finished in a natural brass finish, reminiscent of hidden treasures resting on the ocean floor.

Each piece features hand-blown glass, evoking the delicate beauty of luminous pearls.

The warm, ambient glow transforms any space, blending artisanal craftsmanship with a sense of discovery.

The Sea Treasure is more than a lighting collection—it's an ode to the ocean's elegance, offering a subtle yet luxurious statement for any interior.

Item nr. PA 790  
Model Sea Treasure table lamp  
Material Casted brass  
Sockets 12x G4 LED, 1W  
Finishes Natural brass\*

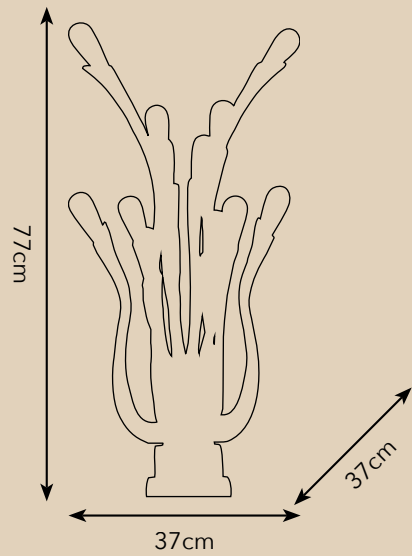

*\*Other aluminium colour on request*



Item nr. PA 791  
Model Sea Treasure wall lamp small  
Material Casted brass  
Sockets 6x G4 LED, 1W  
Finishes Natural brass\*

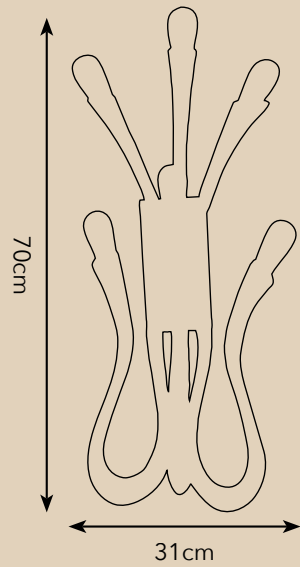

*\*Other aluminium colour on request*





Item nr. PA 793  
Model Sea Treasure hanging lamp  
Material Casted brass  
Sockets 12x G4 LED, 1W  
Finishes Natural brass\*

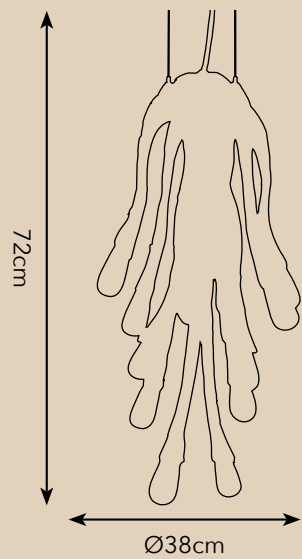

\*Other aluminium colour on request



Item nr. PA 794  
Model Sea Treasure wall lamp large - left  
Material Casted brass  
Sockets 4x G4 LED, 1W  
Finishes Natural brass\*

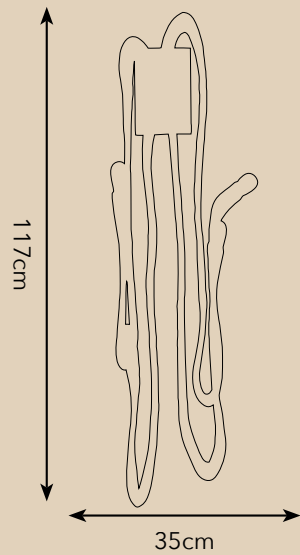

*\*Other aluminium colour on request*



Item nr. PA 795  
Model Sea Treasure wall lamp large - right  
Material Casted brass  
Sockets 4x G4 LED, 1W  
Finishes Natural brass\*

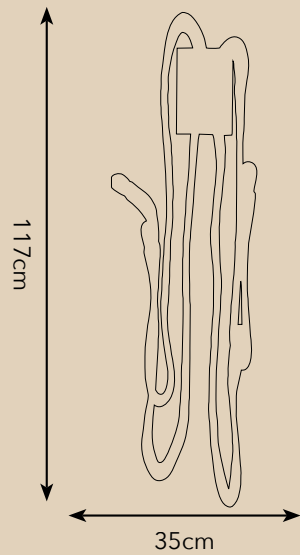

\*Other aluminium colour on request





## CURVA CULTA

The Curva Culta series is Pieter Adam's newest line of luxurious lighting. Pieter got inspired by the work of architect Zaha Hadid and fashion designer Iris van Herpen, which you will see back in the flowing and wavy shapes of the lighting pieces.

A combination of materials is used, such as high quality aluminium, brass and blown glass. The bodies are nicely finished in nature inspired colours. With its bulky curves, the table lamps, wall lamps and hanging lamps, get that distinctive and unique look and twist. This series is very eye catching and perfectly suitable in many interiors.

# CURVA CULTA

- Item nr. PA 740
- Model Curva Cultra table lamp
- Material Casted brass, aluminium
- Shade 7029 bamboo silk
- Sockets 2x E27 max. 60 Watt
- Finishes Dutch silver, **natural brass\***

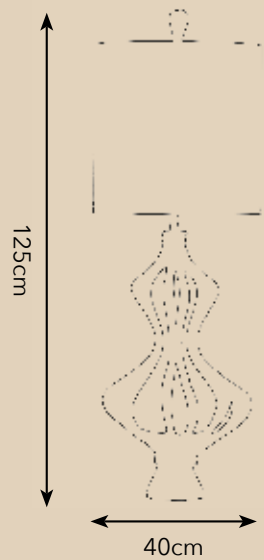

*\*Other aluminium colour on request*

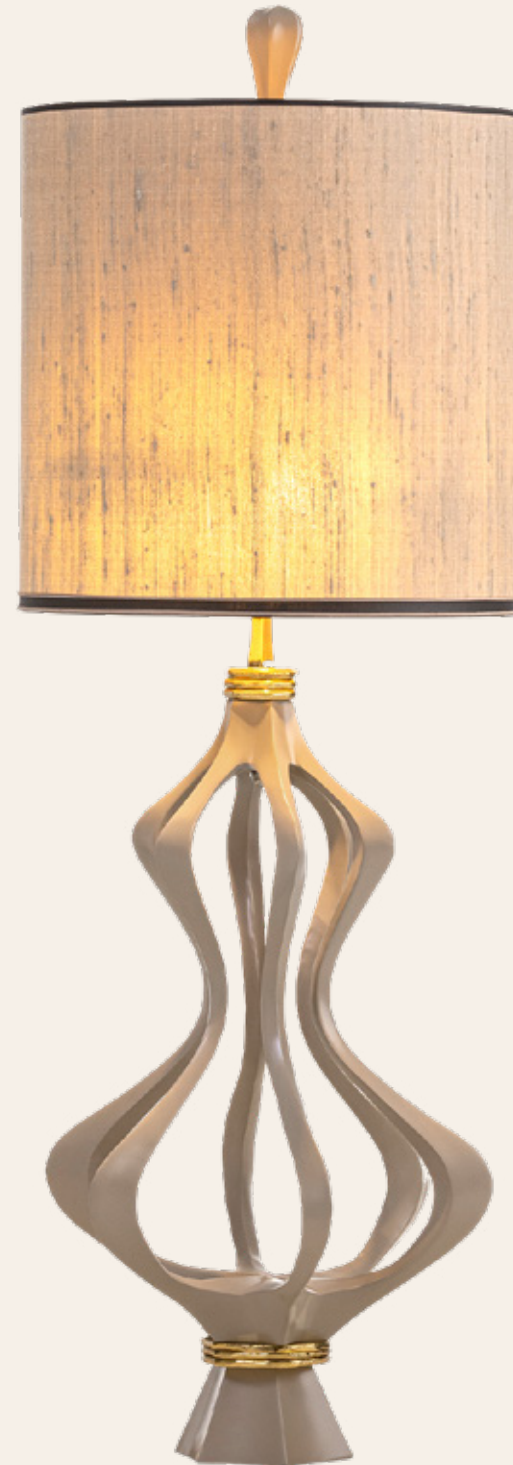

# CURVA CULTA

- Item nr PA 741
- Model Curva Culpa table lamp with glass
- Material Casted brass, aluminium, glass
- Shade 8309 dark blue
- Sockets 2x E27 max. 60 Watt, 1x G9
- Finishes Dutch silver, natural brass\*



\*Other aluminium colour on request





A tall, ornate silver candle holder with multiple tiers and arms, holding several lit white candles. The holder has a textured, possibly crystal or glass, finish. It sits on a round coffee table with a black and white checkered top.

A modern lamp with a large, dark blue cylindrical shade. The base is a dark, sculptural piece with a central glowing orb. It sits on a round coffee table with a black and white checkered top.

A tiered, dark-colored decorative object, possibly a vase or a small sculpture, with a pointed top and a flared base. It sits on a round coffee table with a black and white checkered top.

A rectangular, tiered decorative table with a green and gold patterned surface. It sits on a dark, stepped platform.

A large, lush green plant with broad leaves, possibly a Philodendron or similar, in a dark, rectangular planter. It is positioned on the left side of the scene.

A large, lush green plant with broad leaves, possibly a Philodendron or similar, in a dark, rectangular planter. It is positioned on the right side of the scene.

# CURVA CULTA

- Item nr PA 760
- Model Curva Culta hanging lamp long big (3 parts)
- Material Casted brass, aluminium, glass
- Sockets 3x G9
- Finishes Dutch silver, natural brass\*

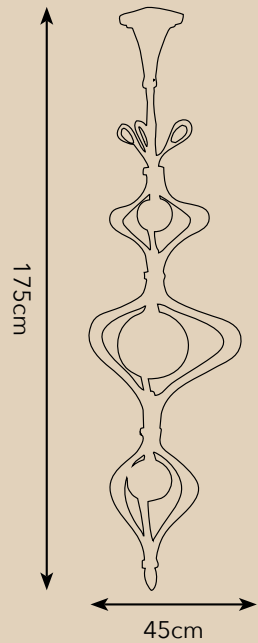

\*Other aluminium colour on request



# CURVA CULTA

- Item nr PA 761
- Model Curva Culta hanging lamp long slim (3 parts)
- Material Casted brass, aluminium, glass
- Sockets 3x G9
- Finishes Dutch silver, natural brass\*

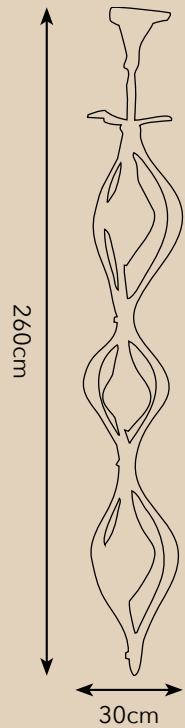

\*Other aluminium colour on request





# CURVA CULTA

Item nr PA 763  
Model Curva Culta hanging lamp short big (1 part)  
Material Casted brass, aluminium, glass  
Sockets 1x G9  
Finishes Dutch silver, natural brass\*

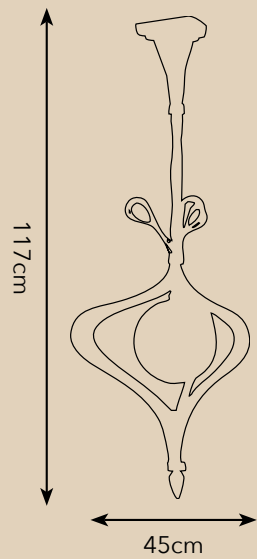

\*Other aluminium colour on request



# CURVA CULTA

Item nr PA 764  
Model Curva Culta hanging lamp short slim (1 part)  
Material Casted brass, aluminium, glass  
Sockets 1x G9  
Finishes Dutch silver, **natural brass\***

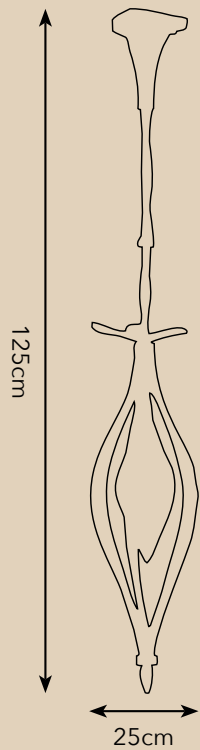

*\*Other aluminium colour on request*



Item nr PA 765  
Model Curva Culta wall lamp slim  
Material Casted brass, aluminium, glass  
Sockets 1x G9 LED  
Finishes Dutch silver, natural brass\*

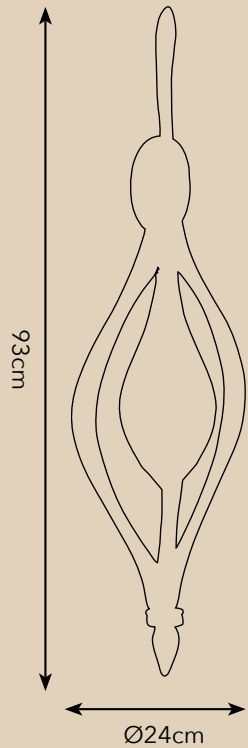

\*Other aluminium colour on request



**Item nr** PA 766  
**Model** Curva Cultra wall lamp big  
**Material** Casted brass, aluminium, glass  
**Sockets** 1x G9 LED  
**Finishes** Dutch silver, natural brass\*

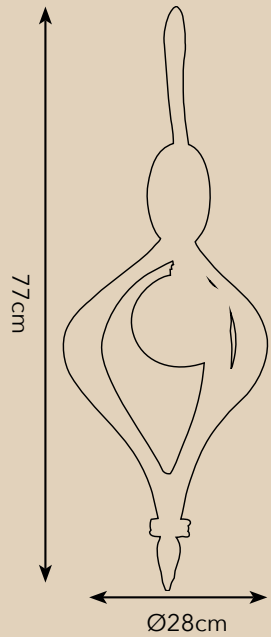

\*Other aluminium colour on request



## MELTING PARADISE

Adding a tropical touch to your interior doesn't have to mean adding an enormous leafy plant. With the Melting Paradise series you're instantly transported to dreamy exotic beaches. Crafted from brass, the leaves and the Murano glass with gold leaf reflect the light beautifully. These super decorative statement pieces will certainly be eye-catching and creating a relaxed ambience in any interior. The sun will come out everywhere you put them- we just cannot get enough of these lights!

Item nr PA 8910  
Model Melting Paradise table lamp  
Material Casted brass, Murano glass  
Sockets 7x G4 LED  
Finishes Natural brass

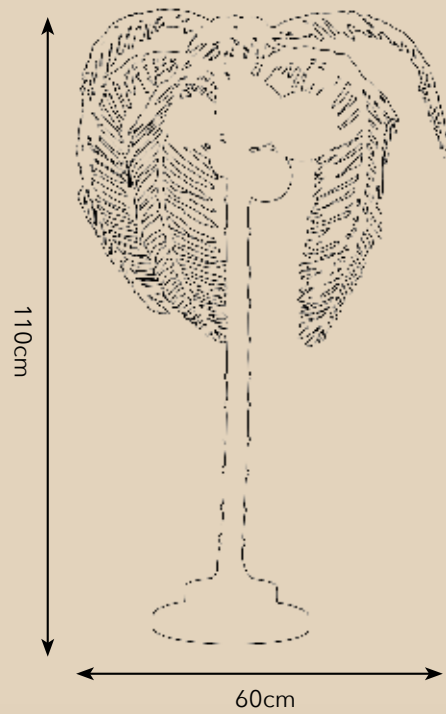

Item nr PA 8911  
Model Melting Paradise floor lamp  
Material Casted brass, Murano glass  
Sockets 7x G4 LED  
Finishes Natural brass

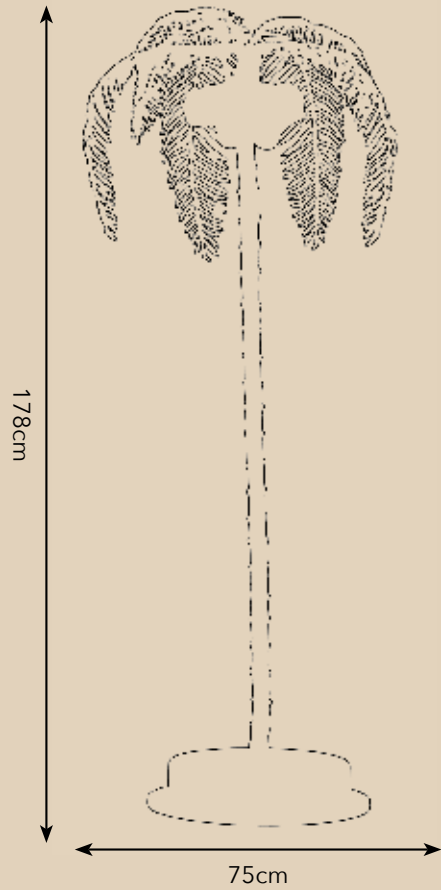







# MELTING PARADISE

**Item nr** PA 8912  
**Model** Melting Paradise hanging lamp  
**Material** Casted brass, Murano glass  
**Sockets** 18x G4 LED  
**Finishes** Natural brass

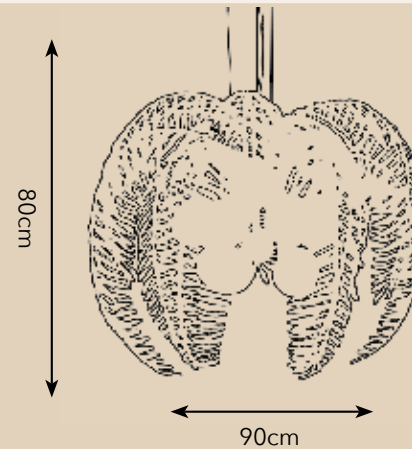

Item nr PA 8913  
Model Melting Paradise floor lamp XL  
Material Casted brass, Murano glass  
Sockets 17x G4 LED  
Finishes Natural brass

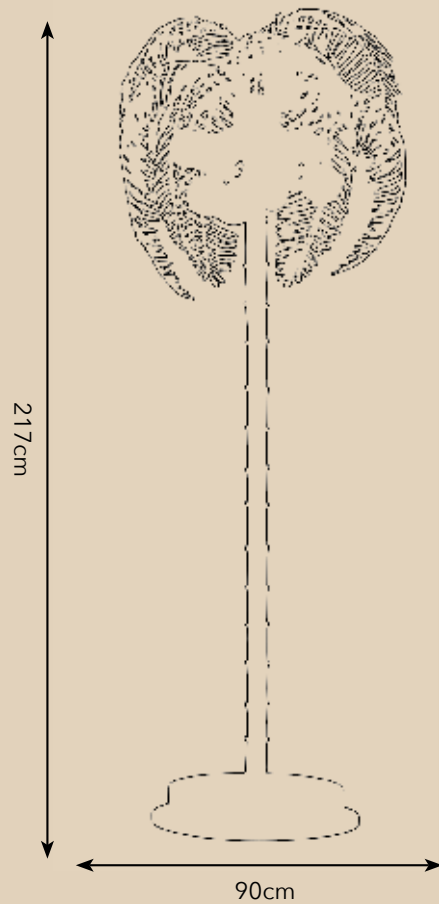



## CARNIFOREST

An ode to nature's beautiful ingeniousness. The gorgeous exterior of the flesh-eating plant conceals its carnivorous nature. Thankfully, Pieter's new design "CarniForest" is not as ruthless as its source of inspiration. Rather, it creates a fairy-like atmosphere. The plant's lid provides the light with a refined reflection. Surrounded by the most beautiful small elements from the forest, the stunning protective shape is what gives this lamp its fabulous magical look.

Item nr. PA 950  
Model CarniForest hanging lamp  
Material Casted Brass  
Sockets 9x G4 LED + GU5.3 LED spot  
Finishes Natural brass / Dutch silver\*



\*For images of the other finishes visit our website >





Item nr. PA 951  
Model CarniForest table lamp  
Material Casted Brass  
Sockets 10x G4 LED  
Finishes Natural brass / Dutch silver\*



*\*For images of the other finishes visit our website >*

Item nr. PA 952  
Model CarniForest wall lamp  
Material Casted Brass  
Sockets 9x G4 LED  
Finishes Natural brass / Dutch silver\*

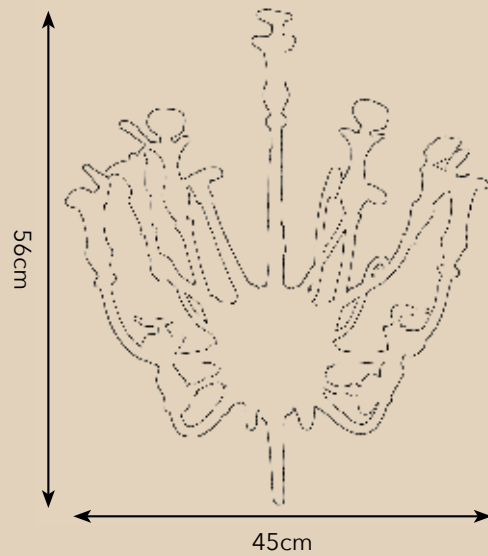

*\*For images of the other finishes visit our website >*







## WORN TORCH

Pieter's preferred method of designing and creating is working manually on an idea and seeing it come to life right under his hands. For this new line of wall lamps, Pieter worked with an unusual material to give shape to his designs. By using polyurethane foam and sanding it down, the designer was able to really finetune his sought-after, "imperfect" shape. Being very three-dimensional and asymmetrical, the wall torch's appearance subtly changes with every change of angle. The typical organic irregularity and softened edges provide its elegant silhouette with a slightly worn-out look. The glass on the other side contrasts the torch with its sleek, geometrical form resembling diamond facet. The matt finish gives the glass, and thereby the light, a beautiful diffusion.

The WornTorch series consists of a single and double wall light. The designs have been brass casted and polished for a chic look and finished in either natural brass or Dutch silver. The length of these wall lights makes them an excellent choice for those seeking to emphasize the height of their space.

Item nr. PA 770  
Model WornTorch 2l  
Material Casted Brass  
Sockets 2x G4 LED  
Finishes Natural brass / Dutch silver

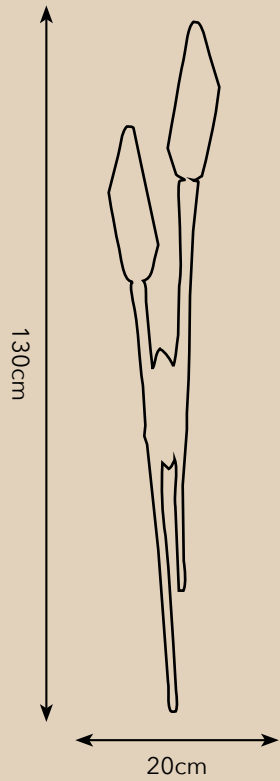

**Item nr.** PA 771  
**Model** WornTorch 1l  
**Material** Casted Brass  
**Sockets** 2x G4 LED  
**Finishes** Natural brass / Dutch silver

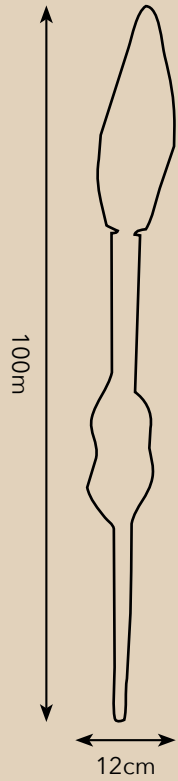



## MYSTERIOUS BAMBOO

Nature can work in mysterious ways, with its grace and curiosity serving as a great source of inspiration. In various Asian cultures bamboo is regarded a symbol for uprightness and tenacity. The plant is often endowed with traits as integrity, elegance, and optimism. The new Mysterious Bamboo series represents Pieter Adam's own interpretation of this noble plant, enriching it with a playfulness, joy and light-heartedness. The integrity and elegance in the detailing shows a great admiration of nature. An excellent choice for anyone looking to implement a botanical, mystic touch to their interior, perfectly fitting the present zeitgeist.

Item nr. PA 901  
Model Mysterious Bamboo table lamp  
Material Casted Brass  
Shade 5305 Pitch Black Silk  
Sockets 5x E14 max. 40Watt  
Finishes Natural brass / Dutch silver\*



*\*For images of the other finishes visit our website >*



Item nr. PA 902  
Model Mysterious Bamboo floor lamp S  
Material Casted Brass  
Shade 5305 Pitch Black Silk  
Sockets 3x E14 max. 40Watt  
Finishes **Natural brass / Dutch silver\***



*\*For images of the other finishes visit our [website](#) >*





*"The only enemy of art is taste!"*

*- Thomas Hoving -*



Item nr. PA 903  
Model Mysterious Bamboo floor lamp XL  
Material Casted Brass  
Shade 5305 Pitch Black Silk  
Sockets 7x E14 max. 40Watt  
Finishes **Natural brass / Dutch silver\***

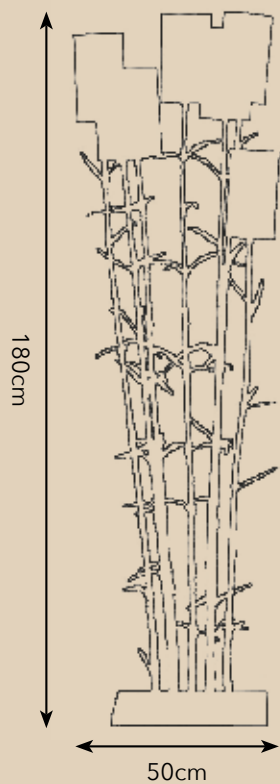

*\*For images of the other finishes visit our [website](#) >*





## MELTING PARIS

The Melting Paris series combines nature's radiance with organic shapes in a contemporary style by employing a raw surface of bronze. Recognizable shapes are restyled to achieve their own look.

In contrast with today's mass production, Pieter Adam wants his designs to show his personal touch and signature. This is clearly visible in the Melting Paris series where each piece is handcrafted in wax literally showing the artists' finger prints. When looking at a Melting piece one can see the organic, unrestricted shape; nothing is straight or smooth. These pieces are characteristic of detail and achievement. The possibilities bronze casting offers are being employed in all its facets.

The freedom of creativity and inspiration is ultimately found in creating something by just using your hands. It is the purest way of designing. Away from all mass produced items and searching for the authentic craftsmanship only traditional craftsmen can achieve. Sustainable, with love for his craft and the end product, a Melting Paris piece truly gives a peek in the artist's head.

**Item nr.** PA 845  
**Model** Melting Paris floor-lamp  
**Material** Casted brass  
**Shade** 8230 Black Leather  
**Sockets** 2x E14 max. 40 Watt  
**Finishes** Dutch Silver / Canadian Gold /  
Smoked Brass / **Rose Gold**

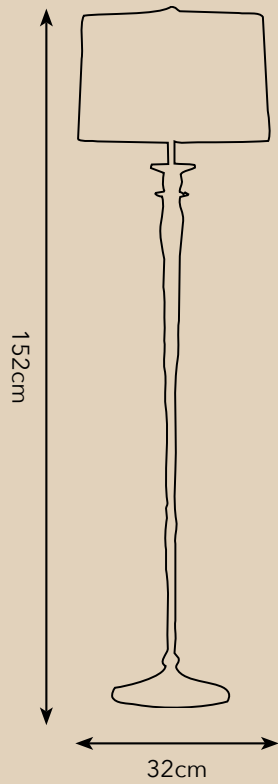

*\*For images of the other finishes visit our [website](#) >*



Item nr. PA 847  
Model Melting Paris table-lamp vase  
Material Casted Brass  
Shade 5300 Forest Linen  
Sockets 2x E27 max. 60Watt  
Finishes Dutch Silver / Canadian Gold /  
Smoked Brass / Rose Gold\*

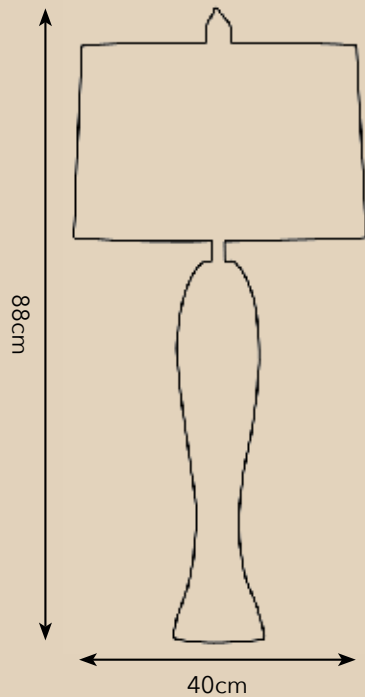

*\*For images of the other finishes visit our website >*





Item nr. PA 849  
Model Melting Paris table-lamp  
Material Casted Brass  
Shade 8259 Ivory Velvet  
Sockets 2x E14 max. 40Watt  
Finishes Dutch Silver / Canadian Gold /  
Smoked Brass / Rose Gold\*

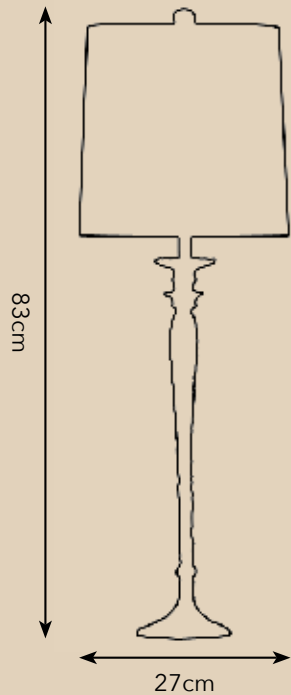

*\*For images of the other finishes visit our website >*



Item nr. PA 849  
Model Melting Paris table-lamp  
Material Casted Brass  
Shade 5300 Forest Linen  
Sockets 2x E14 max. 40Watt  
Finishes Dutch Silver / **Canadian Gold** /  
Smoked Brass / Rose Gold\*

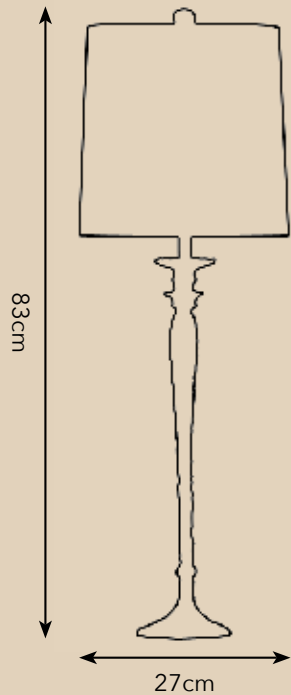

*\*For images of the other finishes visit our [website](#) >*



**Item nr.** PA 856  
**Model** Melting Paris wall-torch long  
**Material** Casted Brass  
**Shade** 5301 Stony ground linen  
**Sockets** E27 max. 60 Watt  
**Finishes** Dutch Silver / Canadian Gold /  
Smoked Brass / Rose Gold\*

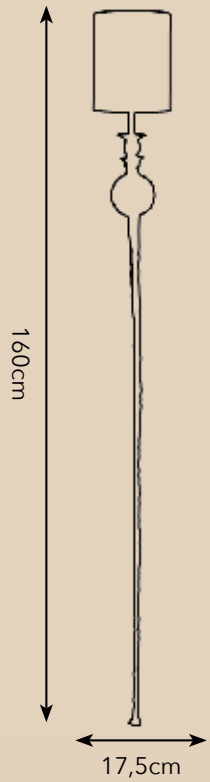

\*For images of the other finishes visit our [website](#) >





Item nr. PA 855  
Model Melting Paris wall-torch  
Material Casted Brass  
Shade 5300 Forest Linen  
Sockets E27 max. 40 Watt  
Finishes Dutch Silver / **Canadian Gold** /  
Smoked Brass / Rose Gold\*

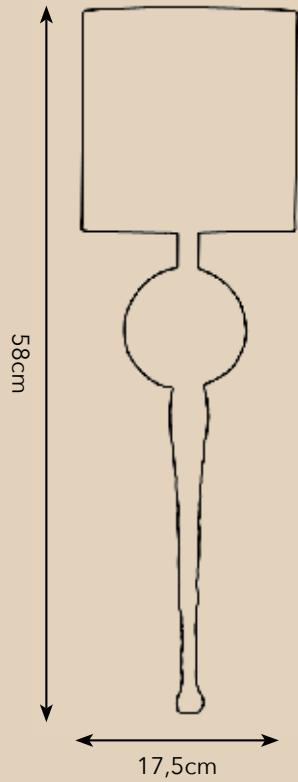

\*For images of the other finishes visit our [website](#) >





Item nr. PA 850  
Model Melting Paris Sunday afternoon woman  
Material Casted Brass  
Shade 8261 Burnished Gold Velvet  
Sockets 2x E14 max. 40 Watt  
Finishes Dutch Silver / **Canadian Gold** / Smoked Brass\*

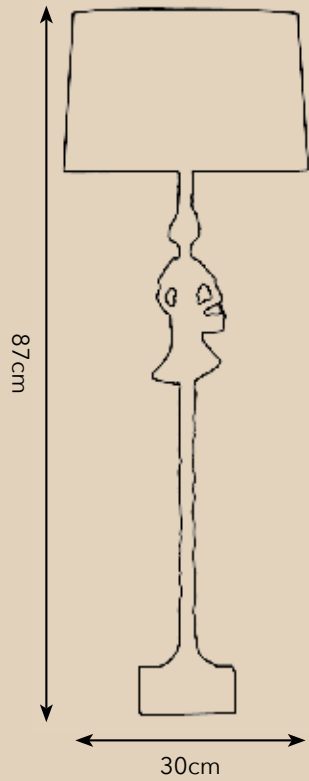

\*For images of the other finishes visit our [website](#) >



Item nr. PA 851  
Model Melting Paris Sunday afternoon man  
Material Casted Brass  
Shade 8261 Burnished Gold Velvet  
Sockets 2x E14 max. 40 Watt  
Finishes Dutch Silver / **Canadian Gold** / Smoked Brass\*

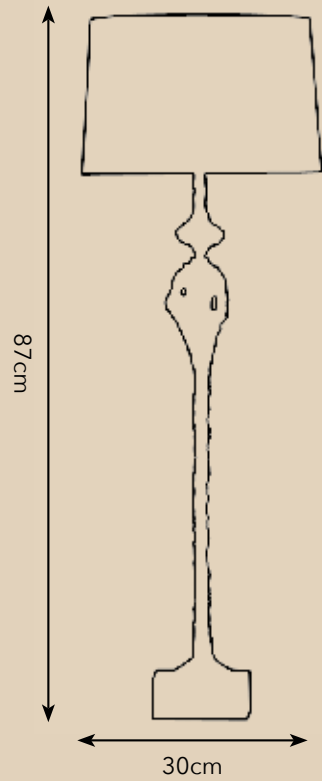

*\*For images of the other finishes visit our [website](#) >*





## TWIGGY

Pieter Adam's Twiggy line comprehends contemporary design and sustainability. Twiggy is a collection based on nature's purest grace. Inspiration was found in the organic, capricious shaping of twigs. Pursuing nature's strength in growing strong and solid with its unequalled, beautiful and characteristic appearance was serving as the main source of inspiration for the designer. Fair materials like brass and glass emphasize the sustainable nature of this collection. Organic shapes casted in brass and crafted with the utmost attention to detail combined with mouthblown glass providing a subtle reflection of the halogen light. Finishes like silver and gold give this lighting series its specific and exclusive radiation.

Look, feel and admire: enjoy nature's beauty where no twigs are alike.



# TWIGGY

- Item nr.** PA 870
- Model** Twiggy hanging lamp small
- Material** Casted brass
- Sockets** 6x G4 12V max. 5 Watt  
halogen spot max. 30 Watt
- Finishes** Dutch Silver / Canadian Gold / Smoked Brass\*

\*For images of the other finishes visit our website >

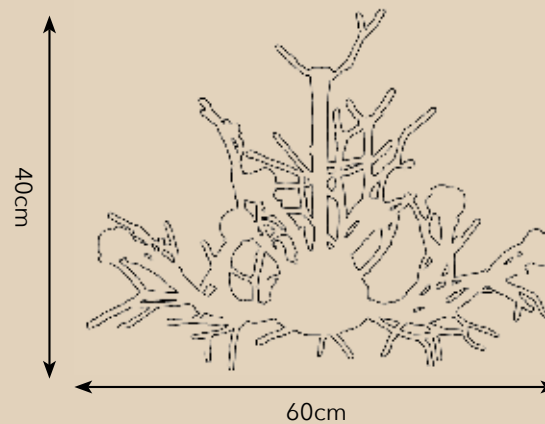



# TWIGGY

- Item nr.** PA 871
- Model** Twiggy hanging lamp medium
- Material** Casted brass
- Sockets** 6x G4 12V max. 5 Watt  
halogen spot max. 30 Watt
- Finishes** Dutch Silver / Canadian Gold / Smoked Brass\*

\*For images of the other finishes visit our [website](#) >

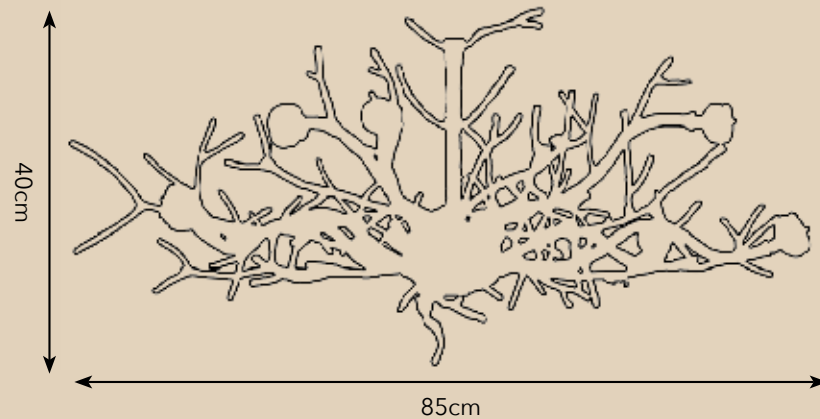







# TWIGGY

- Item nr.** PA 872
- Model** Twiggy hanging lamp large
- Material** Casted brass
- Sockets** 12x G4 12V max. 5 Watt  
halogen spot max. 30 Watt
- Finishes** Dutch Silver / Canadian Gold / Smoked Brass\*

\*For images of the other finishes visit our [website](#) >





# TWIGGY

- Item nr. PA 878
- Model TwiggY hanging lamp oval XL
- Material Casted brass
- Sockets 12x G4 12V max. 5 Watt  
halogen spot max. 30 Watt
- Finishes Dutch Silver / Canadian Gold / **Smoked Brass\***

*\*For images of the other finishes visit our website >*

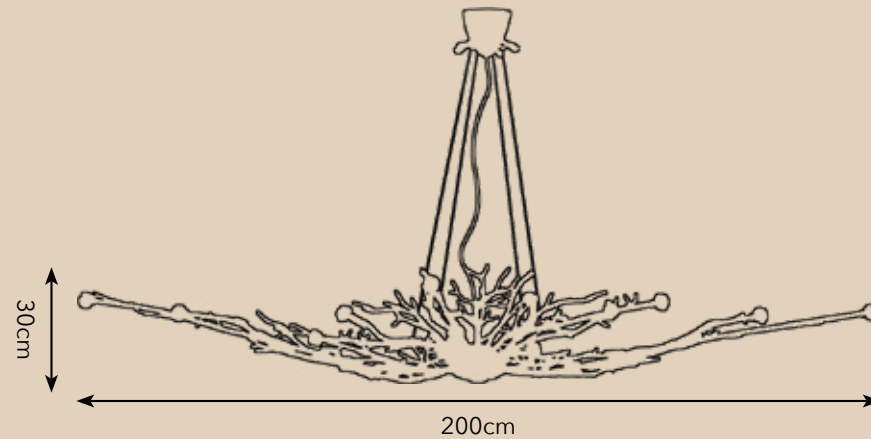

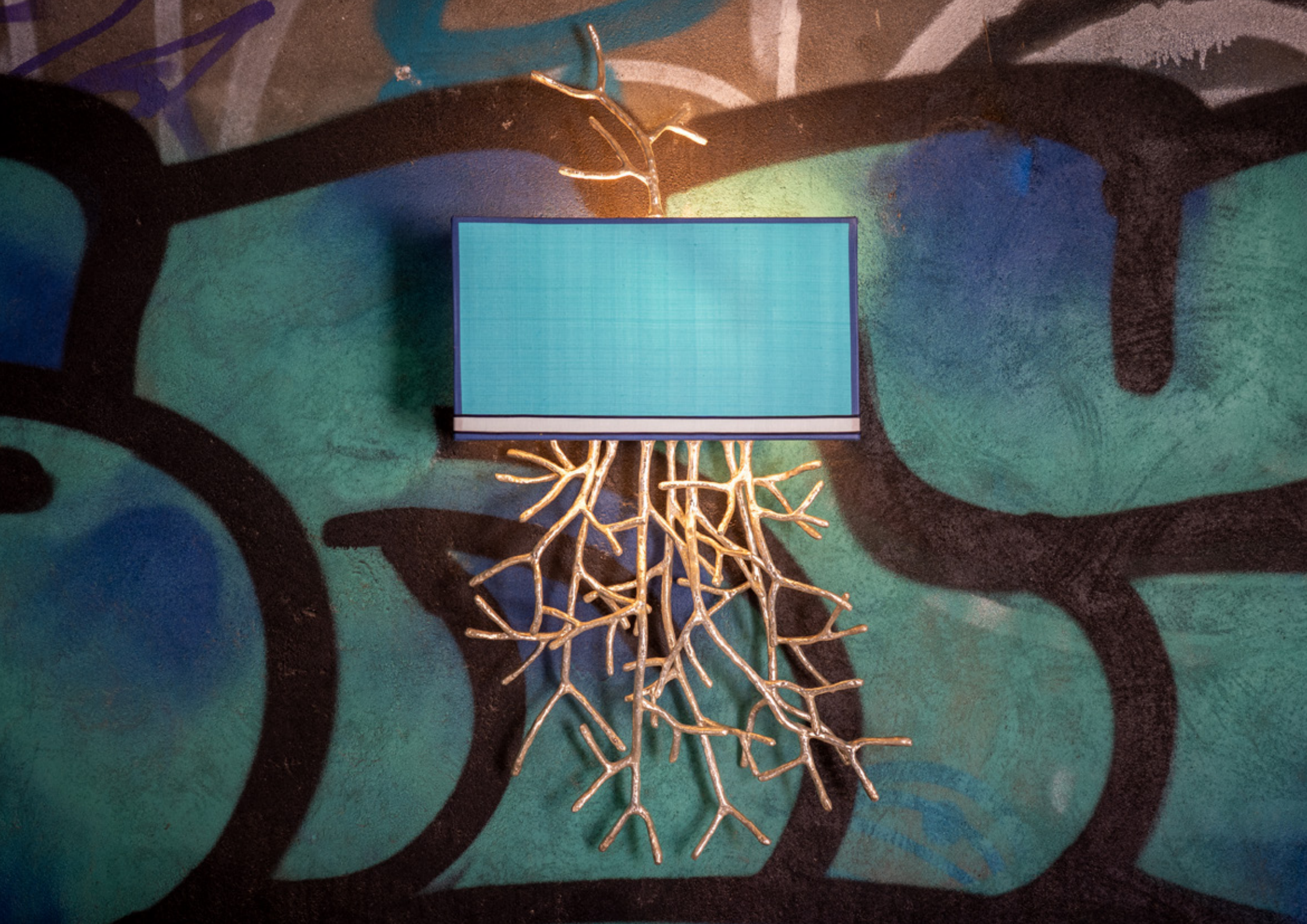

Item nr. PA 875  
Model Twiggy wall-sconce  
Material Casted brass  
Shade 8111 Champagne Silk  
Sockets 2x E14 max. 40Watt  
Finishes Dutch Silver / **Canadian Gold** / Smoked Brass\*

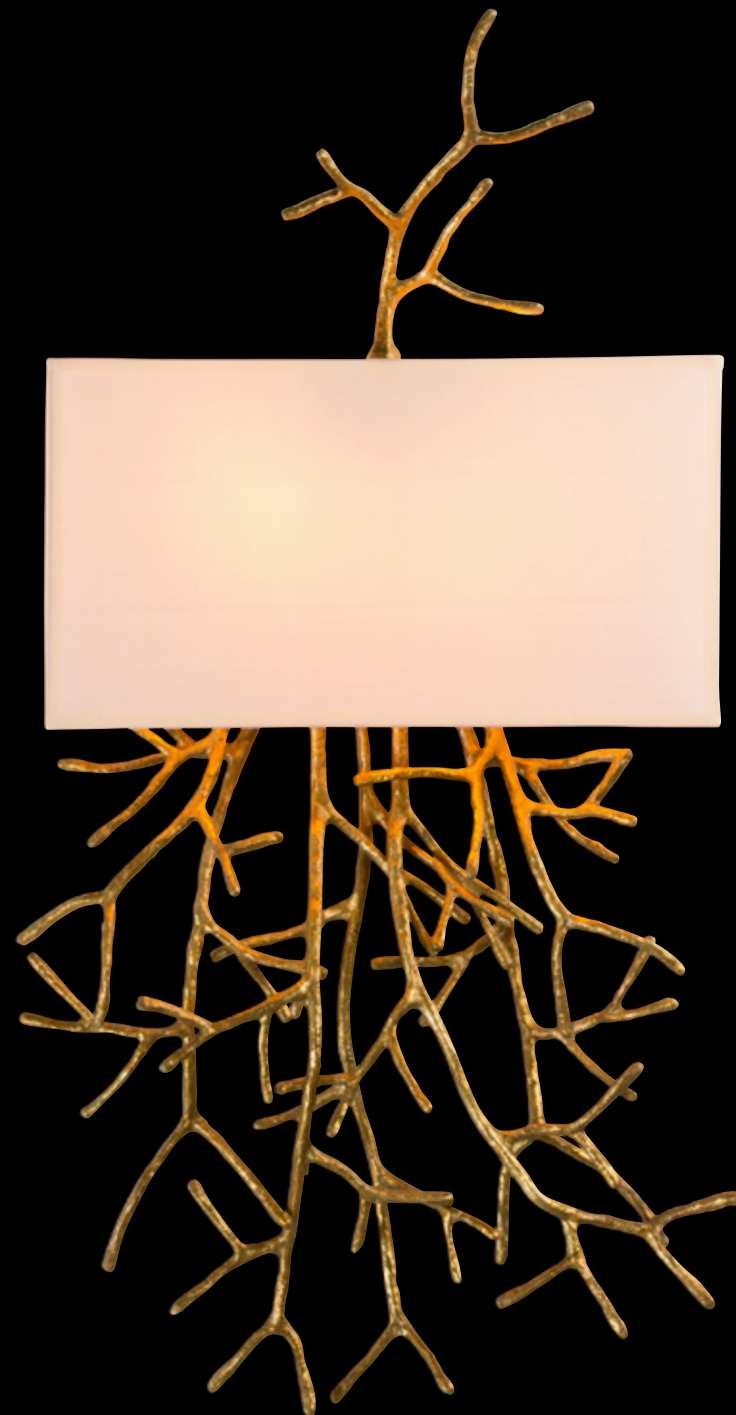
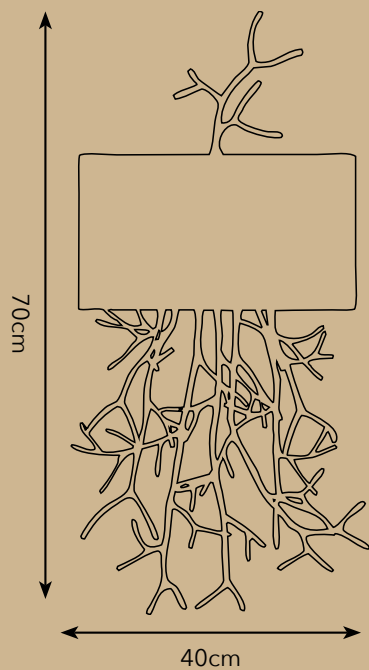

\*For images of the other finishes visit our website >

Item nr. PA 875  
 Model Twiggy wall-sconce  
 Material Casted brass  
 Shade 5306 Pitch Black Silk  
 Sockets 2x E14 max. 40Watt  
 Finishes Dutch Silver / Canadian Gold / Smoked Brass\*

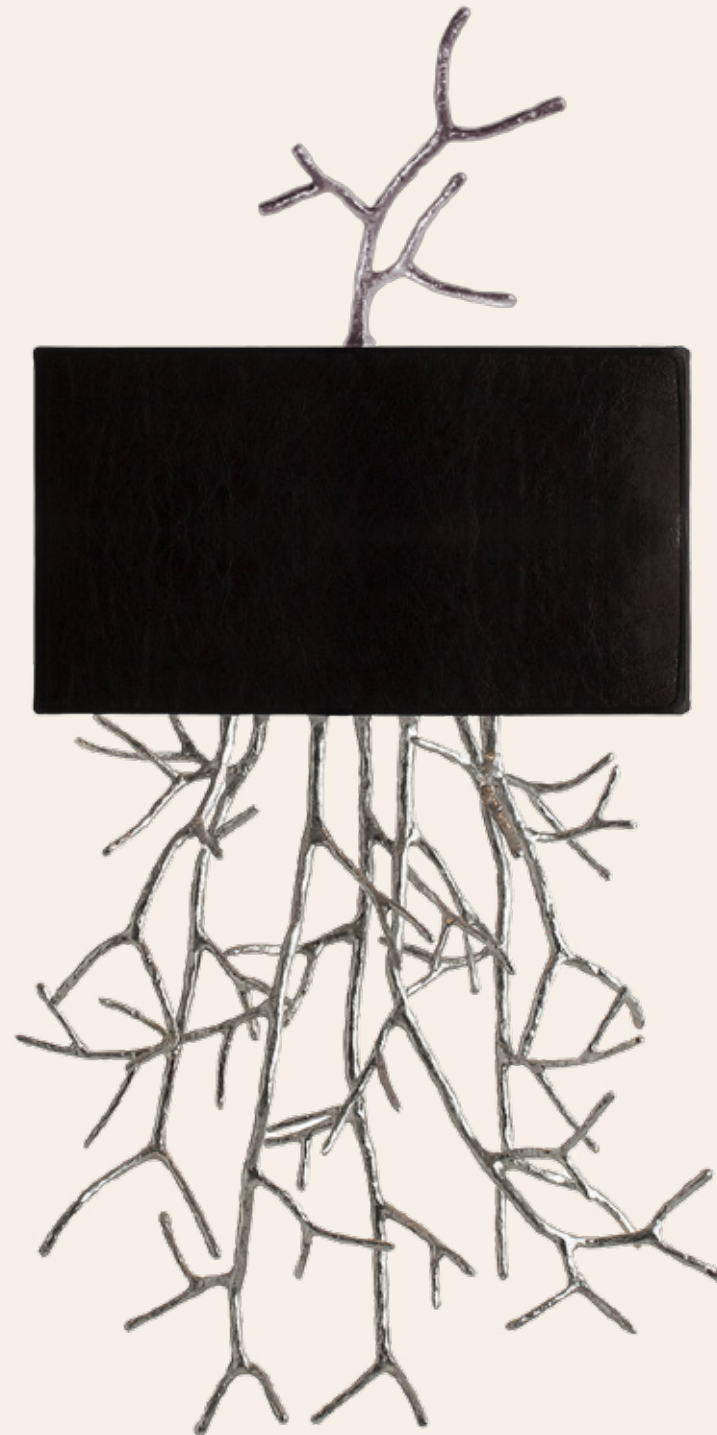
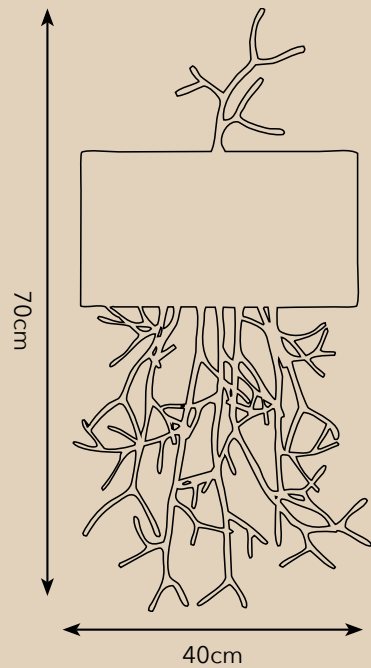

\*For images of the other finishes visit our website >



PIETER ADAM

**Item nr.** PA 873  
**Model** Twiggy table lamp XL  
**Material** Casted brass  
**Shade** 5306 Pitch Black Silk  
**Sockets** 4x E14 max. 40 Watt  
**Finishes** Dutch Silver / Canadian Gold / Smoked Brass

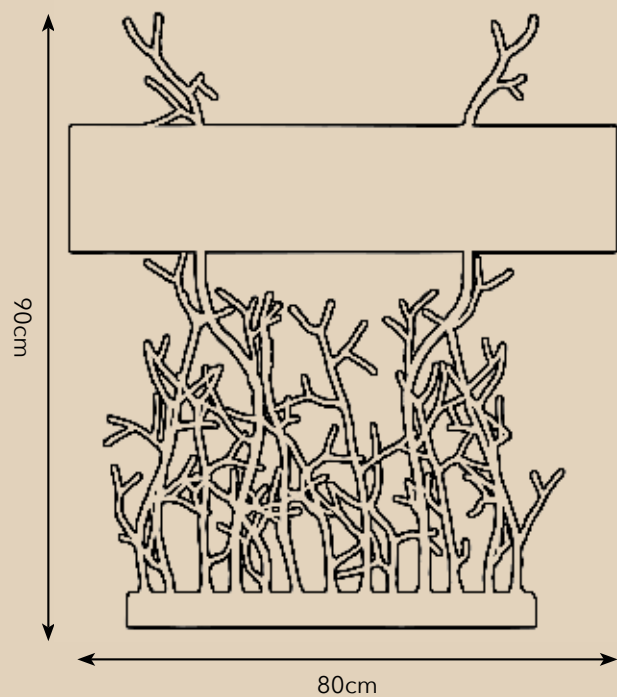

*\*For images of the other finishes visit our website >*

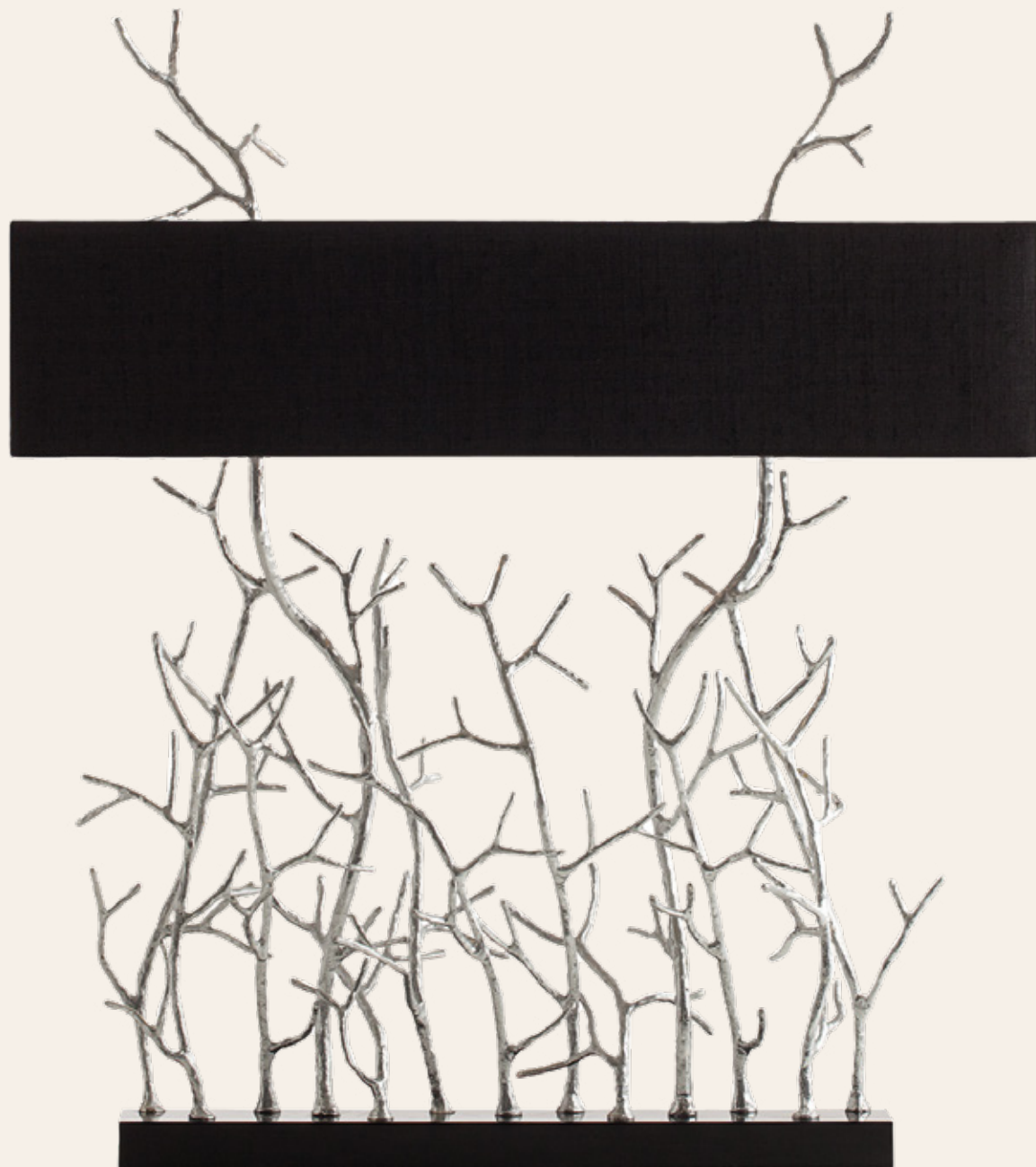

**Item nr.** PA 874  
**Model** Twiggy table lamp high  
**Material** Casted brass  
**Shade** 5306 Pitch Black Silk  
**Sockets** 2x E14 max. 40 Watt  
**Finishes** Dutch Silver / Canadian Gold / Smoked Brass

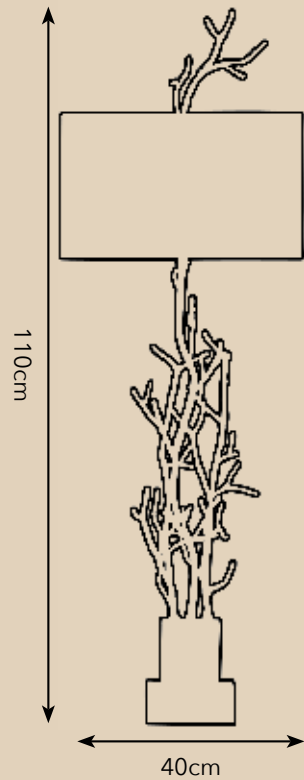

*\*For images of the other finishes visit our [website](#) >*





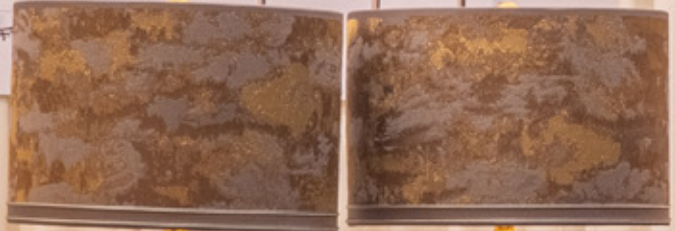

Item nr. PA 876  
 Model Twiggy floor lamp  
 Material Casted brass  
 Shade 5305 Pitch Black Silk  
 Sockets 2x E14 max. 40 Watt  
 Finishes Dutch Silver / **Canadian Gold** / Smoked Brass



*\*For images of the other finishes visit our website >*



Item nr. PA 877  
 Model Twiggy floor lamp XL  
 Material Casted brass  
 Shade 8111 Champagne Silk  
 Sockets 2x E14 max. 40 Watt  
 Finishes Dutch Silver / Canadian Gold / Smoked Brass

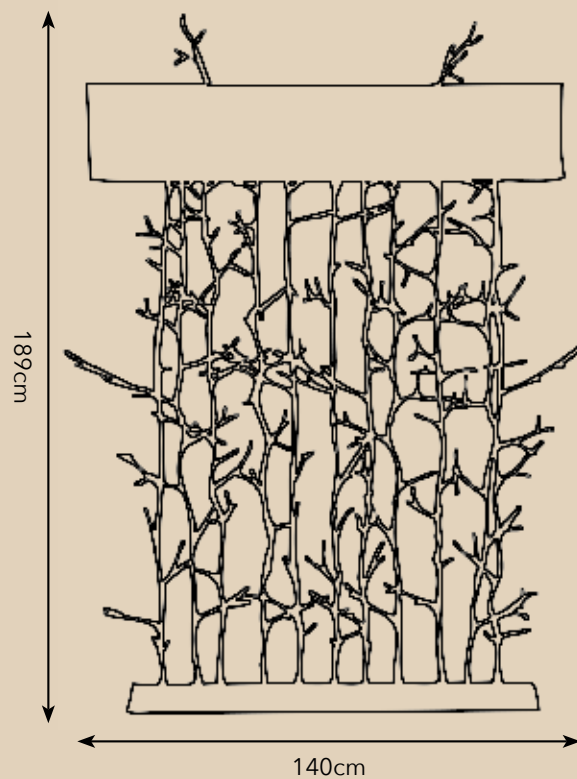

*\*For images of the other finishes visit our website >*





## ROSEDALE

A real Pieter Adam piece plays with different materials. The elegance and lightness of the blown glass contradict the shape of the metal which gives a Rosedale piece its distinctive and playful quality thus ensuring its own identity and recognition. The glass beautifully absorbs any colour and the combination of materials engages the light in a very unique way.

The Rosedale series encompasses transparency and exclusivity offering plenty possibilities when you need a real glamour piece. Whether placed in a five-star hotel lobby or in your residence, these eye catchers complement any interior.

Timeless and with a great adaptability, a Rosedale piece easily integrates in its environment while leaving a great impression through its stylish appearance.

Item nr. PA 821  
Model Rosedale table-lamp  
Material Casted brass/Blown Glass  
Shade 5301 Stony Ground Linen  
Sockets 2x E27 max. 60 Watt  
Finishes Dutch Silver / Canadian Gold / Smoked Brass\*

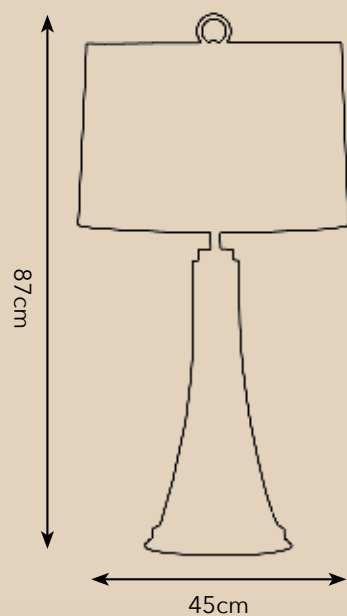

\*For images of the other finishes visit our website >

Itemnr PA 821  
Model Rosedale table-lamp  
Material Casted brass/Blown Glass  
Shade 8214 Saffron Black  
Sockets 2x E27 max. 60 Watt  
Finishes Dutch Silver / Canadian Gold / Smoked Brass\*

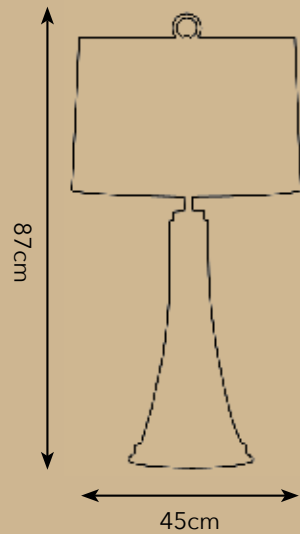

*\*For images of the other finishes visit our website >*



Item nr. PA 823  
Model Rosedale table-lamp  
Material Casted brass/Blown Glass  
Shade 5305 Pitch Black Silk  
Sockets 2x E27 max. 60 Watt  
Finishes Dutch Silver / Canadian Gold /  
Smoked Brass / **Rose Gold\***

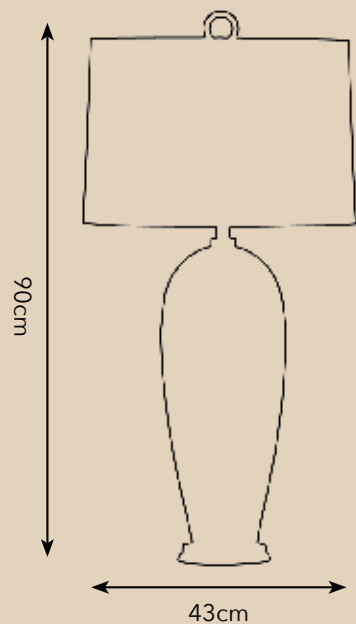

*\*For images of the other finishes visit our website >*







Item nr.	PA 822
Model	Rosedale table-lamp big
Material	Casted brass/Blown Glass
Shade	5305 Pitch Black Silk
Sockets	2x E27 max. 60 Watt
Finishes	Dutch Silver / Canadian Gold / Smoked Brass / <b>Rose Gold*</b>

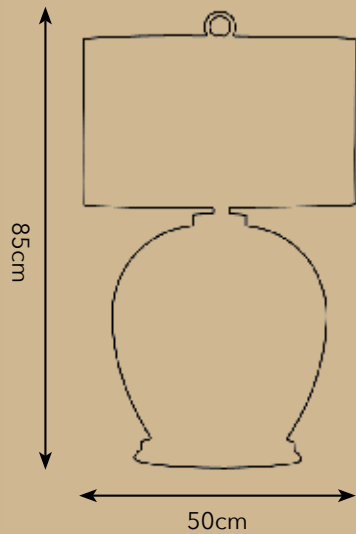

*\*For images of the other finishes visit our website >*



Item nr. PA 824  
Model Rosedale hanging lamp round  
Material Casted brass/Blown glass  
Socket E27 max. 60Wat  
Finishes Dutch Silver / Canadian Gold / Rose Gold\*

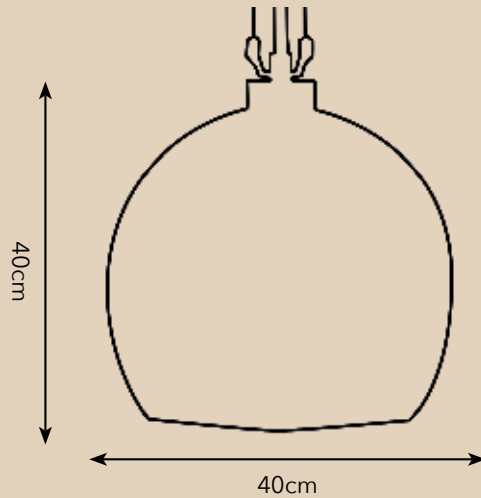

*\*For images of the other finishes visit our website >*

Item nr. PA 826  
Model Rosedale hanging lamp oval  
Material Casted brass/Blown glass  
Socket E27 max. 60Wat  
Finishes Dutch Silver / Canadian Gold / Rose Gold\*

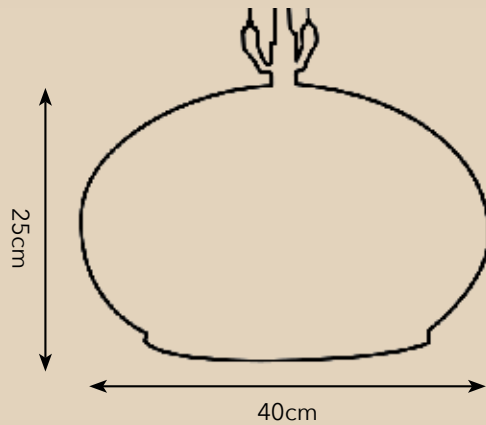

\*For images of the other finishes visit our website >





## LE SOLEIL

Pieter Adam's Le Soleil design encompasses the shape and warm shine of a radiant sun. Nature's beauty has always been a main source of inspiration for the Pieter Adam collection and this was no different for the Le Soleil design. A natural shape made of bronze, with a closed inner circle and an outer circle scattering rays of light. This sculpture has a very pleasant and warm appearance. It can be adjusted to the wall, as well as to the ceiling, ensuring an unique diffusion of light. Le Soleil is available in four sizes and in the finishes bronze, silver and gold. Contemporary and subtle design are characteristic for the Pieter Adam collection and for this, Le Soleil is no exception.

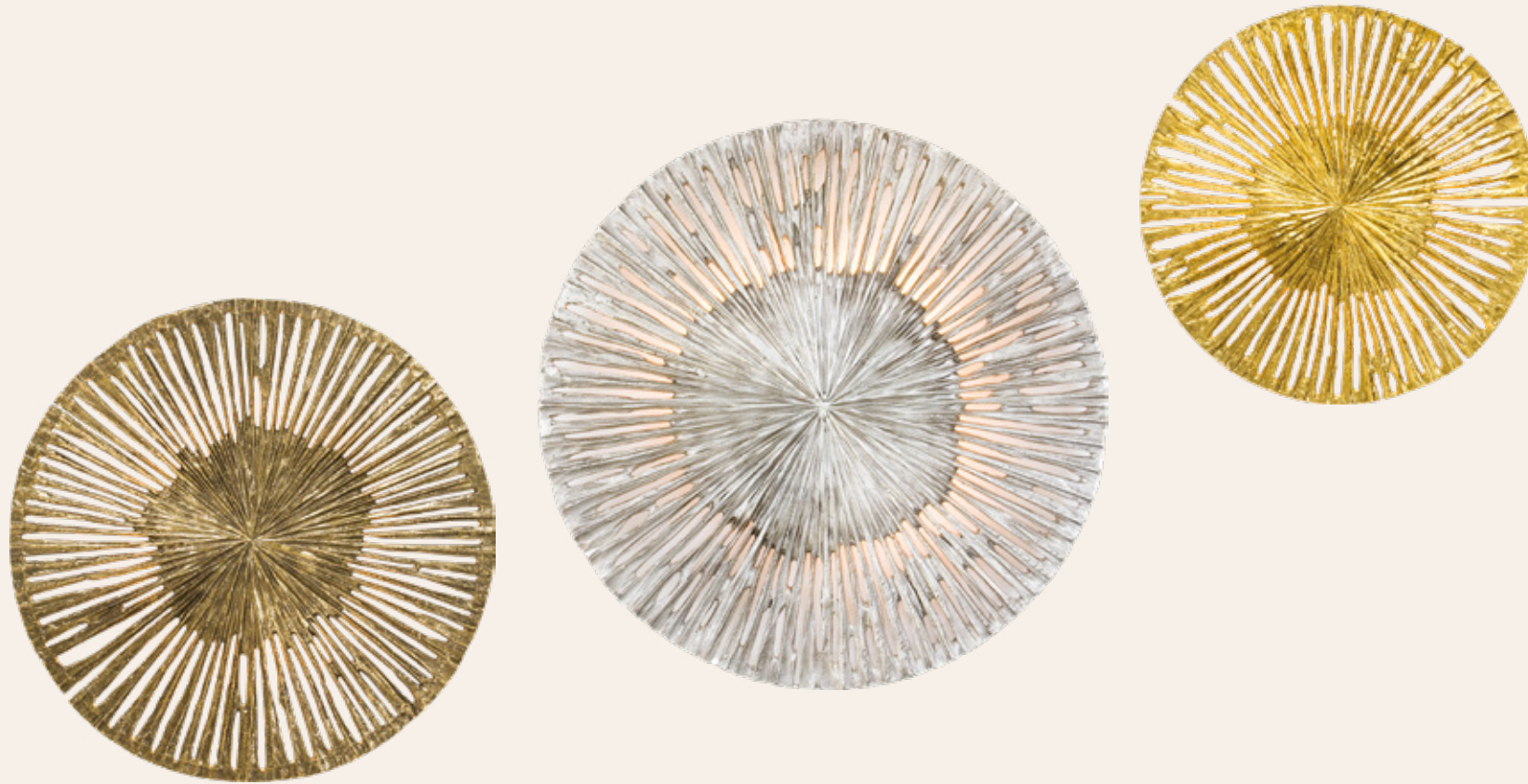

# LE SOLEIL

Itemnr PA 200 - 30cm / PA 201 - 40cm / PA 202 - 60cm / PA 203 - 80cm  
Model Le Soleil wall lamp  
Material Casted brass  
Sockets 6x max. 1 Watt G4 LED  
Finishes Vintage Silver / Vintage Gold / Smoked brass\*

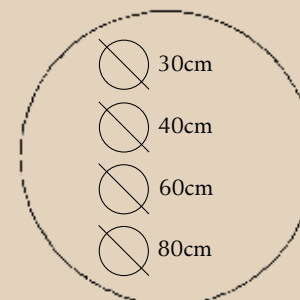

\*For images of the other finishes visit our website >

PIETER ADAM  
CONTEMPORARY DESIGN





## ORGANIC ATOMIC

As its name indicates, the design of Organic Atomic is reminiscent of the smallest particle that an element can be reduced to. This lighting object resembles the organic both systematic composition of everything we see around us. Based on the organic work of art, the spheres are connected in a way that the whole forms an impressive and striking piece of lighting. The Murano glasses with silver leaf are specially blown and designed for this new Pieter Adam series. Sculpted by hand and casted in brass, the connecting pieces can be linked in many ways providing endless possibilities for customization. This leaves lighting architects the opportunity to give their own interpretation to this design and fit it perfectly into their lighting projects.



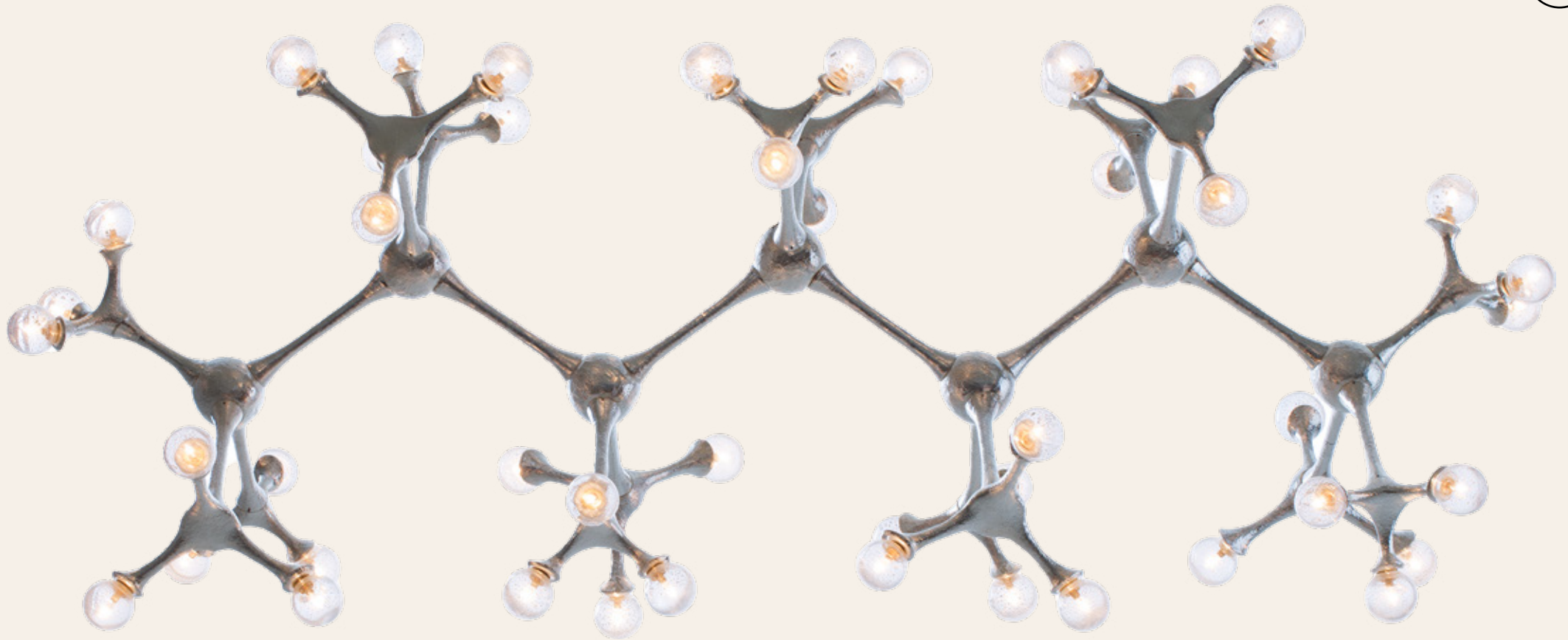

# ORGANIC ATOMIC

**Item nr.** PA 891  
**Model** Organic Atomic hanging lamp XL  
**Sockets** 48x G4 LED  
**Dimensions** L185 x D70 x H75 cm  
**Finish** Dutch Silver / Canadian Gold\*

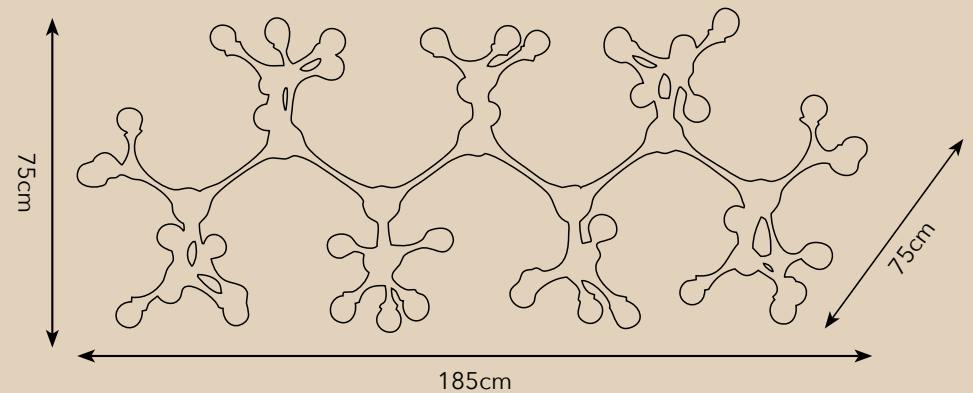

\*Custom sizes on request. For images of the other finishes visit our [website](#) >



**Item nr.** PA 892  
**Model** Organic Atomic hanging lamp  
**Sockets** 45x G4 LED  
**Dimensions** L90 x D80 x H95 cm  
**Finish** Dutch Silver / Canadian Gold\*

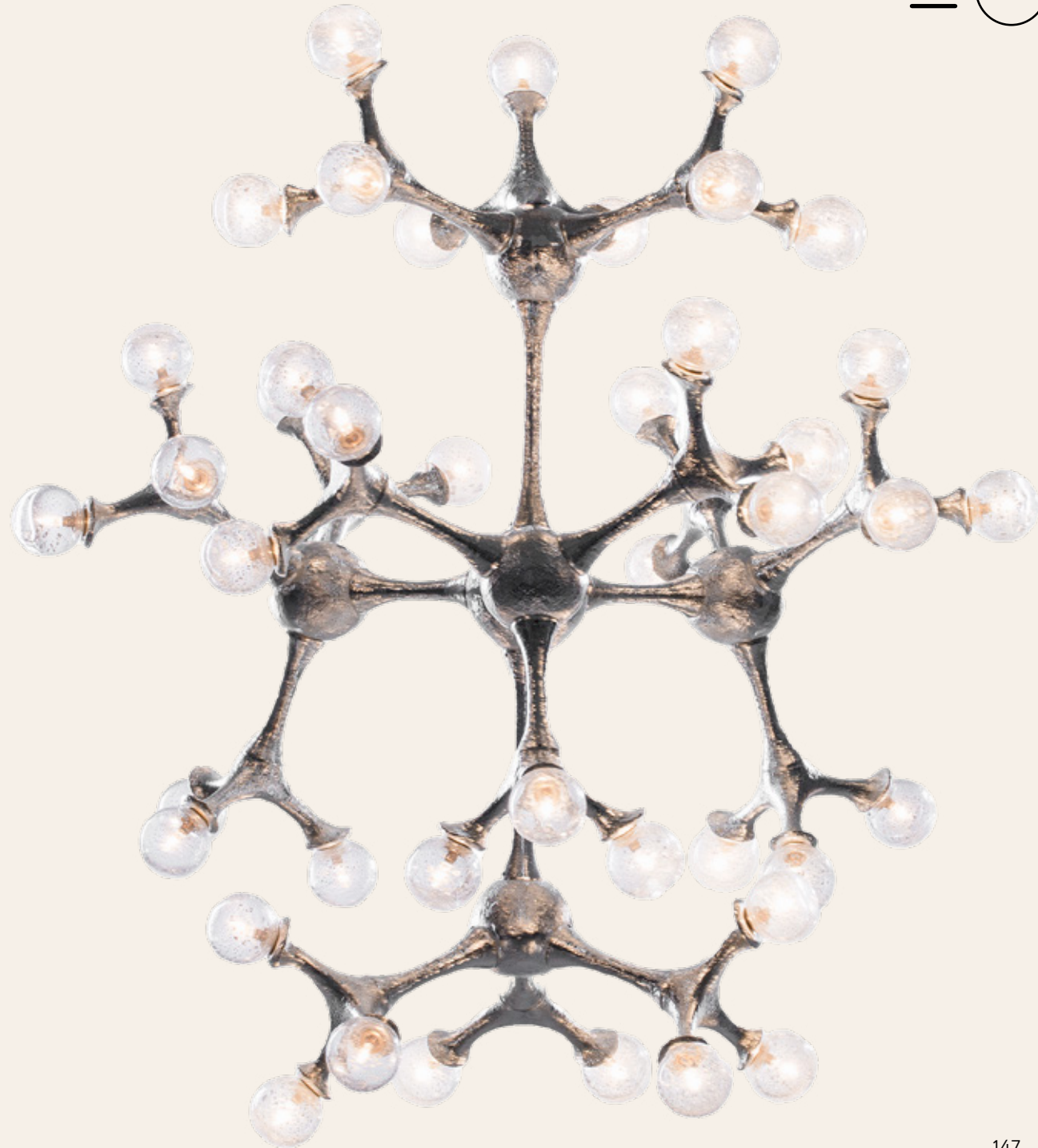
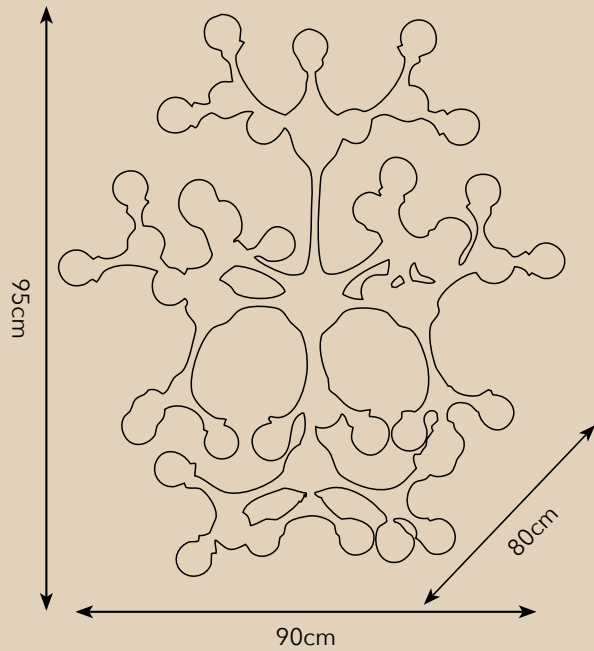

\*Custom sizes on request.  
 For images of the other finishes visit our [website](#) >



**Item nr.** PA 893  
**Model** Organic Atomic wall sconce  
**Sockets** 9x G4 LED  
**Dimensions** L50 x D40 x H55 cm  
**Finish** Dutch Silver / Canadian Gold

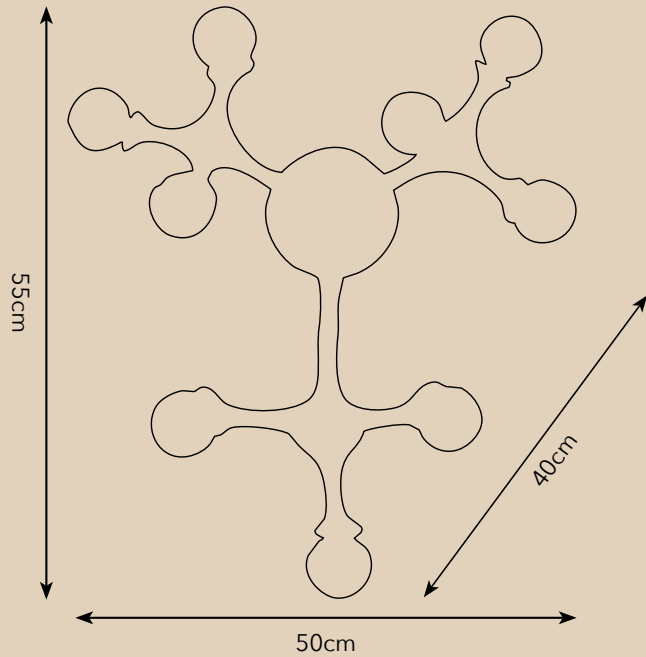

*\*Custom sizes on request.*

*For images of the other finishes visit our [website](#) >*



**Item nr.** PA 897  
**Model** Organic Atomic table lamp  
**Sockets** 21x G4 LED  
**Dimensions** 65 x H65 cm  
**Finish** Oxid silver / Oxid green /  
 Other finishes on request

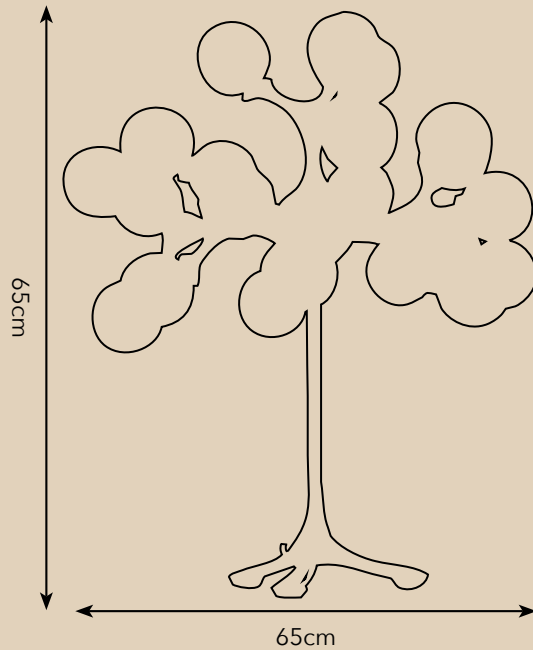

*\*Custom sizes on request.  
 For images of the other finishes visit our [website](#) >*



THE COMPLETE ZAHA HADID  
ARCHITECTURE AND DESIGN  
TECHNICAL DRAWINGS  
PRODUCT DESIGN  
PRESENTATION



Item nr.	PA 894
Model	Organic Atomic lamp round XL
Sockets	75x G4 LED
Dimensions	Ø120 cm / Ø 80cm
Finish	Oxid silver / Oxid green / Other finishes on request

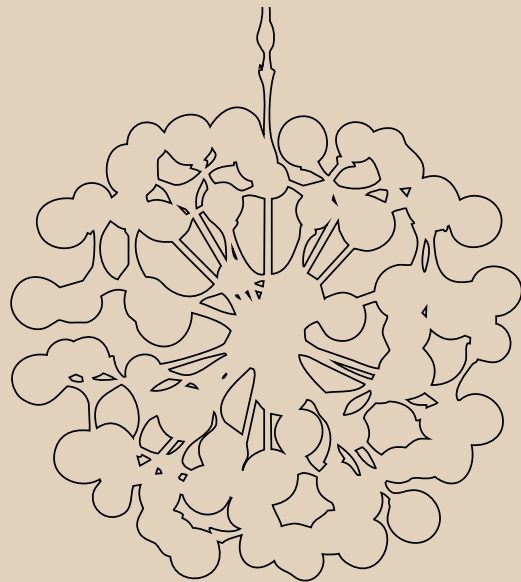

Ø120cm / Ø80cm



\* Custom sizes on request.

For images of the other finishes visit our [website](#) >





## PAUEMENT

The special look and feel that the combination of brass and ceramics creates, is fully exploited in this new series "Pavement". The tension between the smooth ceramics and the raw structure of the brass is as pleasant as it is elegant. The Pavement structure is build up from all kinds of small 'pebbles' of which no one is alike. All these pebbles have been carved out one-by-one by hand in wax and placed criss-cross for a beautiful, natural effect. The shape of stacked parts, alternating between brass and ceramics, show the powerful effect of pattern and repetition.

Item nr. PA 940 / PA 941  
Model Pavement table lamp big  
Material Casted brass + Ceramics  
Shade 5038 gold silk  
Sockets 2x E27  
Finishes **Natural brass / Dutch silver\***

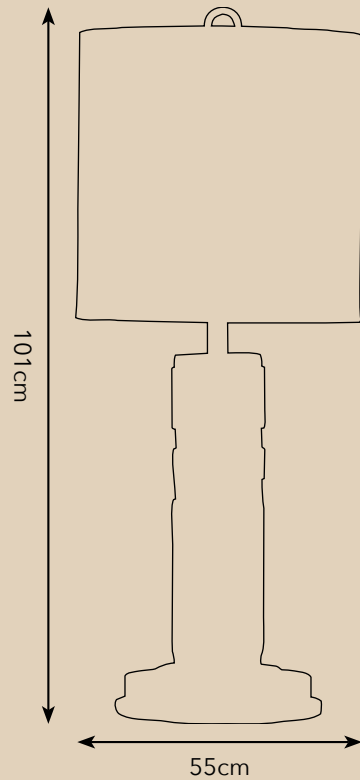

*\*For images of the other finishes visit our website >*



Item nr. PA 942/ PA 943  
Model Pavement table lamp slim  
Material Casted brass + Ceramics  
Shade 8255 Charcoal gray satin  
Sockets 2x E27  
Finishes **Natural brass / Dutch silver\***

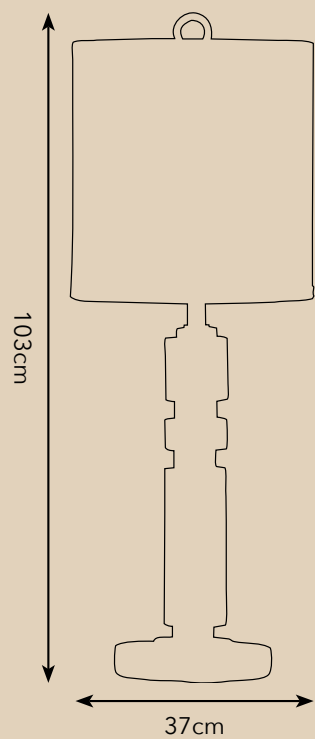

*\*For images of the other finishes visit our website >*



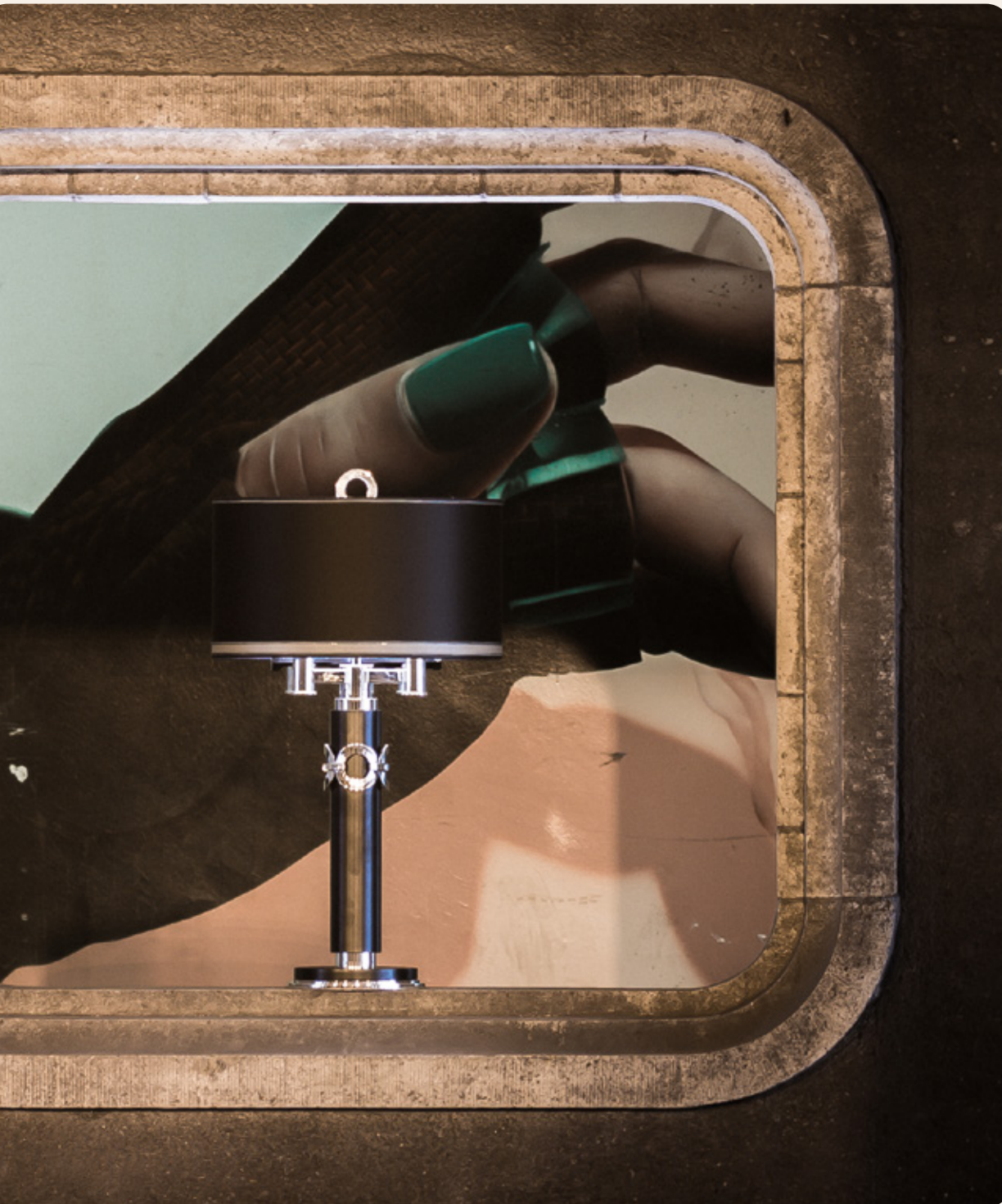

## BRONX

The Bronx series exemplifies lighting with an international radiance. The Pieter Adam logo, circular interconnecting links, returns frequently within these series. These rings are very recognizable and give this series its own identity.

Inspiration for this series was found in refined traditional workmanship on the one hand and the dynamic development of the new era on the other resulting in an unpretentious design employing geometrical patterns and clean lines.

The Bronx style resembles the Art Deco looks. In the late 19th and early 20th century, the Art Deco workmanship was highly valued and appreciated. Also for this series, a lot of patience and expertise is demanded from our bronze founders. A laborious process, recurring in for example the separate moulding of each ring, which is subsequently melted onto the connecting piece. Polished, silver/gold plated and varnished, each piece is made with the utmost attention to perfection.

Item nr. PA 801  
Model Bronx wall-sconce  
Material Casted brass  
Sockets E27 max. 60 Watt  
Finishes Dutch Silver / Canadian Gold /  
**Smoked Brass** / Retro Blond\*

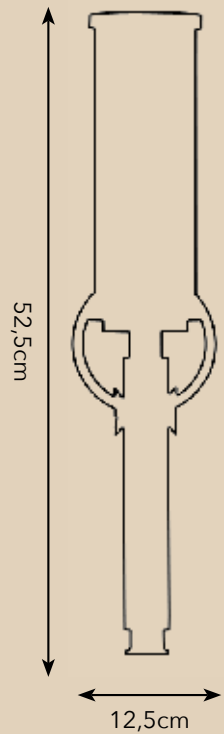

\*For images of the other finishes visit our [website](#) >





# BRONX

- Item nr. PA 802
- Model Bronx wall-sconce
- Material Casted brass
- Shade 8214 Saffron Black
- Sockets 2x E14 max. 60 Watt
- Finishes Dutch Silver / **Canadian Gold** / **Smoked Brass** / Retro Blond\*

\*For images of the other finishes visit our website >

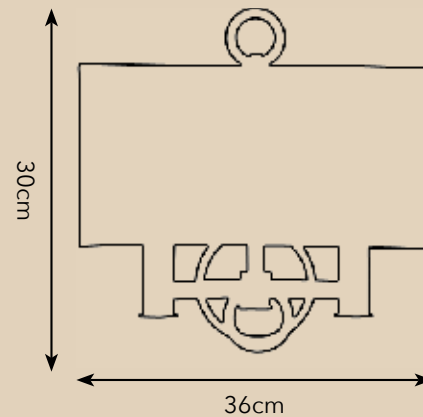





Item nr. PA 809  
Model Bronx table-lamp  
Material Casted brass  
Shade D186 Black Gold Silk  
Sockets 4x E14 max. 40 Watt  
Finishes Dutch Silver / **Canadian Gold** /  
Smoked Brass / Retro Blond\*

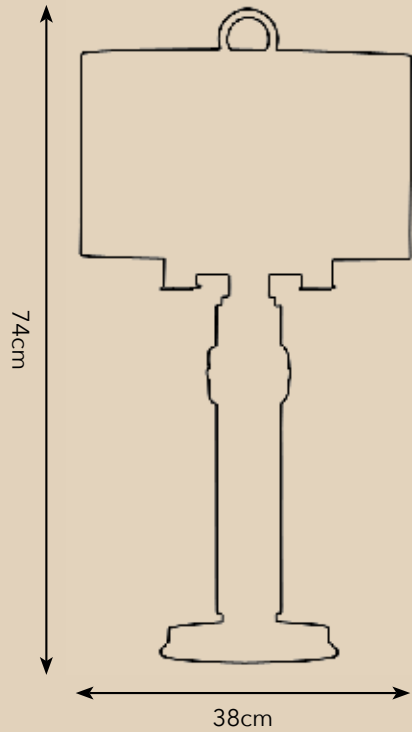

\*For images of the other finishes visit our website >

Item nr. PA 804  
Model Bronx floor-lamp  
Material Casted brass  
Shade D186 Black Gold Silk  
Sockets 4x E14 max. 40 Watt  
Finishes Dutch Silver / Canadian Gold /  
Smoked Brass / Retro Blond\*

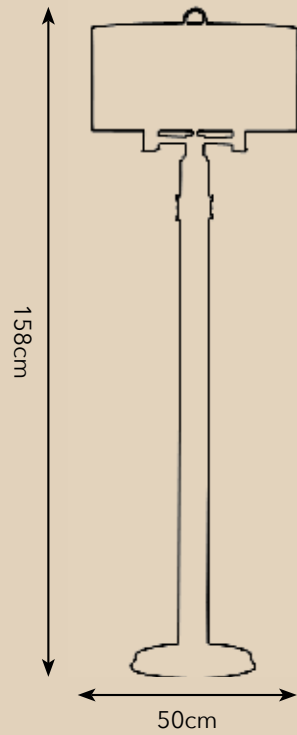

\*For images of the other finishes visit our [website](#) >



- Item nr. PA 831  
Model Pendant Bronx 4 shades  
Material Casted brass  
Shade 8273 Cracked Glossy Black  
Sockets 4x E27 max. 60 Watt, 1x GU 10 220V  
halogen spotlight max. 50 Watt  
Finishes Dutch Silver / Canadian Gold /  
Smoked Brass / Retro Blond\*

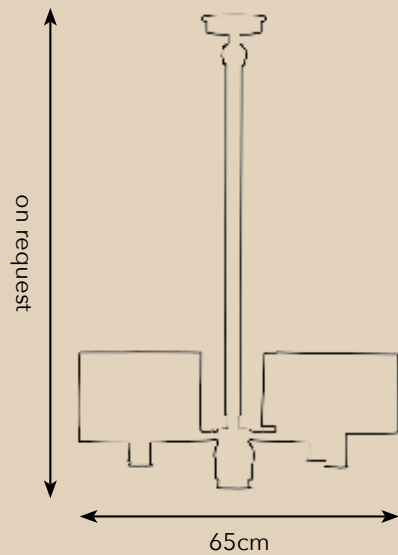

\*For images of the other finishes visit our website >







# BRONX

- Item nr. PA 830
- Model Pendant Bronx 8 shades
- Material Casted brass
- Shade 5301 Stony Ground Linen
- Sockets 8x E27 max. 60 Watt, 2x GU 10 220V halogen spotlight max. 50 Watt
- Finishes Dutch Silver / Canadian Gold / Smoked Brass / Retro Blond\*

\*For images of the other finishes visit our [website](#) >

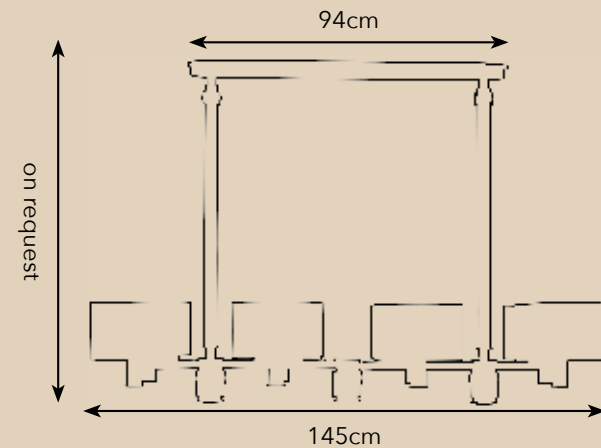



## MELTING AMSTERDAM

Our capital Amsterdam has a rich history and has been a cultural melting pot for many centuries. As a result, the city has its own identity with freedom and individuality being its main traits. This is also true of the new collection designed by Pieter Adam™. The copper-tinted chandeliers of the Golden Age were a source of inspiration for this unique line of lighting fixtures. Tradition and craftsmanship are applied in a contemporary way bringing the past, present and future together. Materials such as gold, silver, Murano glass, silk and brass casted in sand are used for their superior quality. The Dutch design of Pieter Adam™ supplies the originality.

Item nr. PA 860  
Model Melting Amsterdam chandelier  
Material Casted Brass  
Shade 8259 Ivory Velvet  
Sockets 6x G4 LED  
Finishes Dutch Silver / Canadian Gold\*

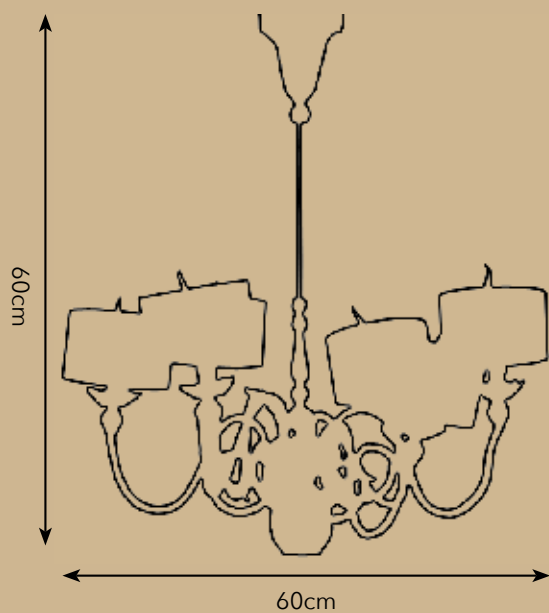

*\*For images of the other finishes visit our website >*





Item nr. PA 861  
Model Melting Amsterdam wall sconce  
Material Casted Brass  
Shade 5305 Pitch Black Silk  
Sockets 3x G4 LED  
Finishes Dutch Silver / Canadian Gold\*

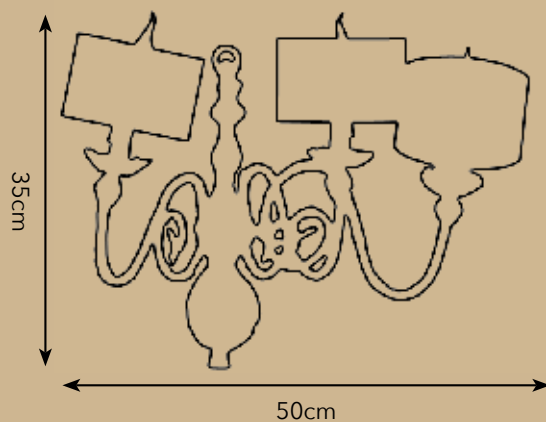

*\*For images of the other finishes visit our website >*

Item nr. PA 865  
Model Melting Amsterdam chandelier XL  
Material Casted Brass  
Shade 8259 Ivory Velvet  
Sockets 12x G4 LED  
Finishes Dutch Silver / Canadian Gold / Rose Gold\*

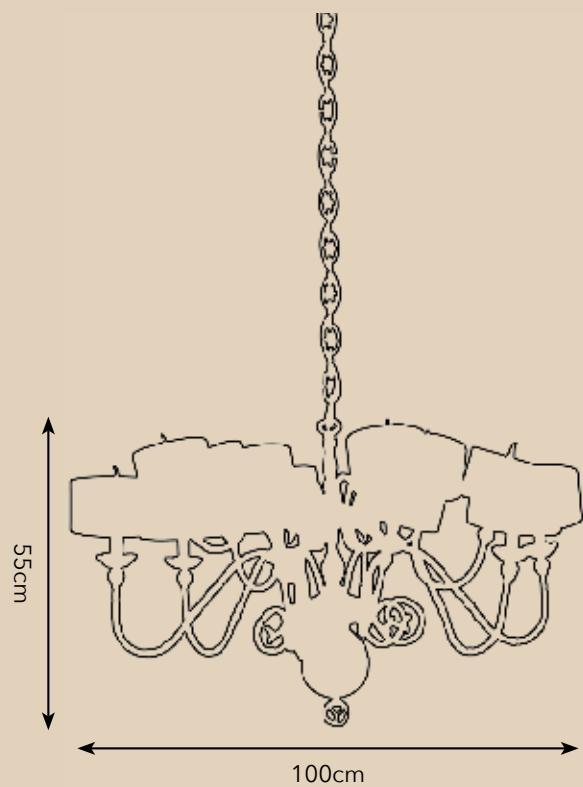

\*For images of the other finishes visit our [website](#) >



Item nr. PA 866  
Model Melting Amsterdam hanging lamp XXL  
Material Casted Brass  
Shade on request  
Sockets 24x G4 LED  
Finishes Dutch Silver / Canadian Gold / Rose Gold\*

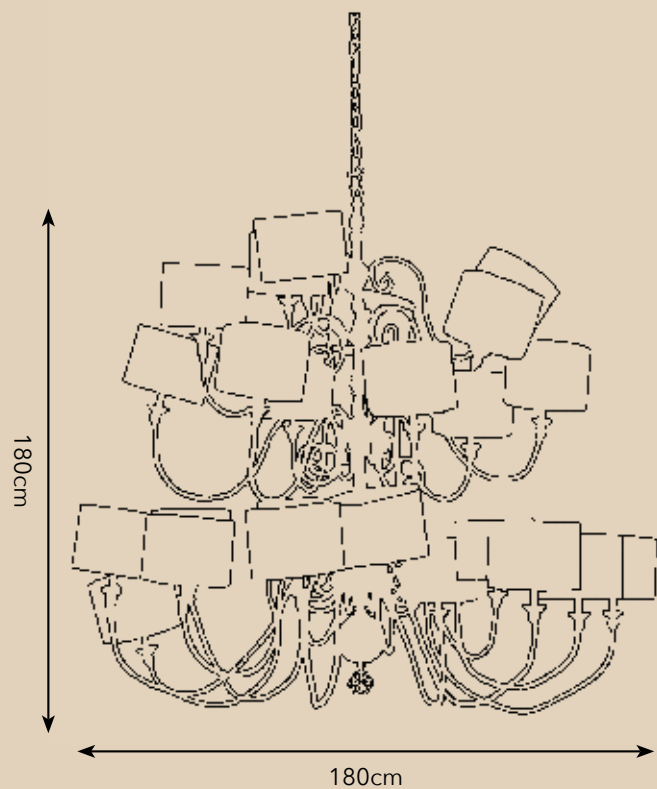

\*For images of the other finishes visit our [website](#) >





## MELTING FEZ

With the Melting Fez series, Pieter Adam shows a new angle on combining varied authentic aesthetics. The sharp-edged curls, a Gothic decorative element, blend beautifully with the Moroccan feel of the lantern. The transparent, delicate fabric combined with the toughness and fickleness of the brass side lines, create a pleasant tension. The light sheltered in the stretched fabric adds a softness and warmth to the mystic sense this design exudes. Mysterious yet frivolous, this lush piece of characteristic lighting merges wonderfully in an ancient ambiance, complementing it with a contemporary twist.

Item nr. PA 501  
Model Melting Fez hanging lamp  
Material Casted Brass  
Sockets 1x E27 max. 60Watt  
Finishes Dutch Silver / Canadian Gold / Dark Bronze\*

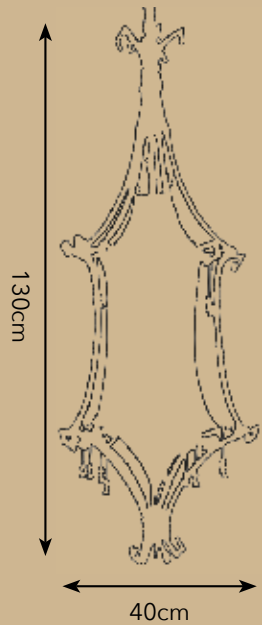

\*For images of the other finishes visit our website >



## MELTING FLORENCE

Melting Florence is Pieter Adam's first series of lighting that can be used both indoors as well as outdoors. The series consist of lanterns with a distinctive twist. The history of lanterns is long standing. Italian lanterns were Pieter's source of inspiration for designing his own version of this centuries-old form of light. As usual , he shows a completely own silhouette corresponding his language of form and shape. The distorted lines and the surprising organic shaping create a completely new interpretation of an ancient type of lighting.

Pieter Adam hopes you will enjoy these objects as much as he enjoyed making them. Fantasy does not know any boundaries.



Item nr. PA 232 - PA 233  
Model Melting Florence wall lantern medium  
Material Casted Brass  
Shade G9 max. 25 Watt  
Finishes Dutch Silver / nickel (*suitable for outdoor use.*)\*

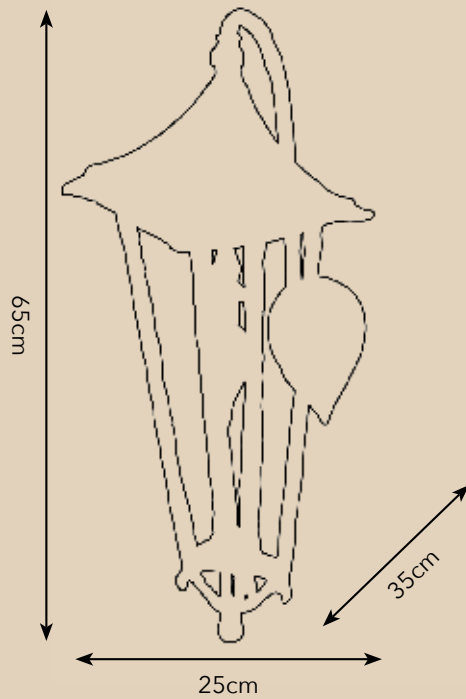

\*For images of the other finishes visit our [website](#) >

Item nr. PA 234 - PA 235  
Model Melting Florence wall lantern large  
Material Casted Brass  
Shade G9 max. 25 Watt  
Finishes Dutch Silver / nickel (*suitable for outdoor use.*)\*

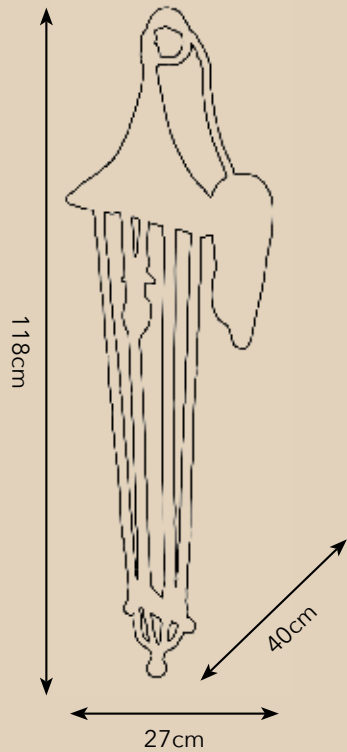

\*For images of the other finishes visit our [website](#) >



## MELTING FLORENCE

- Item nr. PA 230 - PA 231
- Model Melting Florence wall lantern small
- Material Casted Brass
- Shade G9 max. 25 Watt
- Finishes Dutch Silver / nickel (*suitable for outdoor use.*)\*

\*For images of the other finishes visit our website >

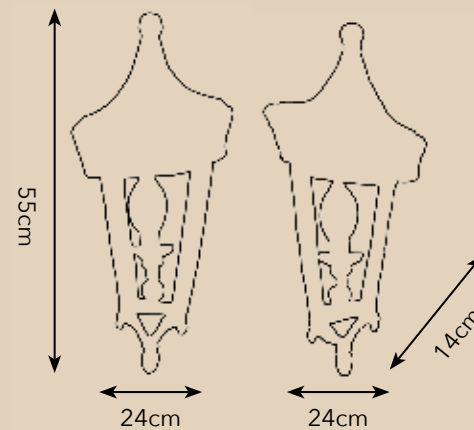

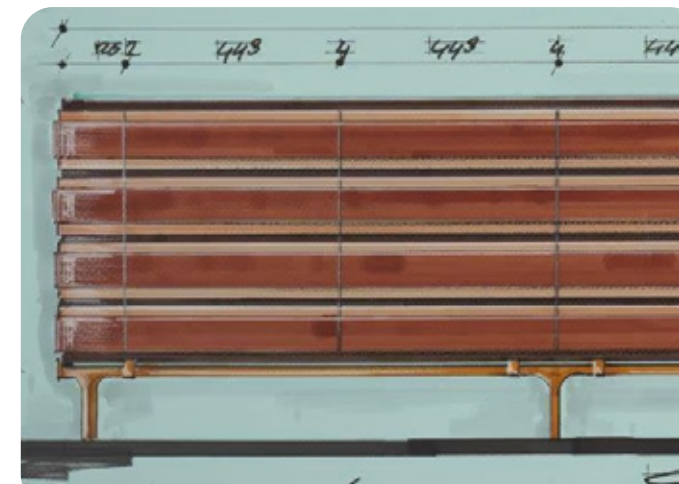
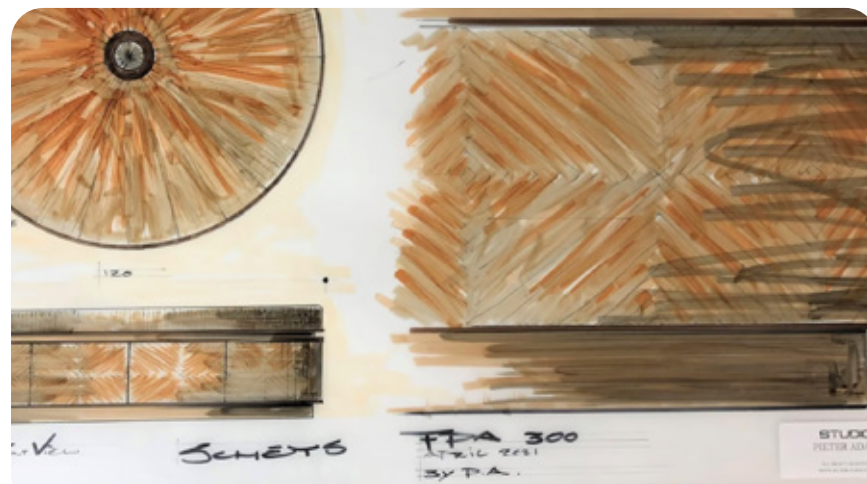
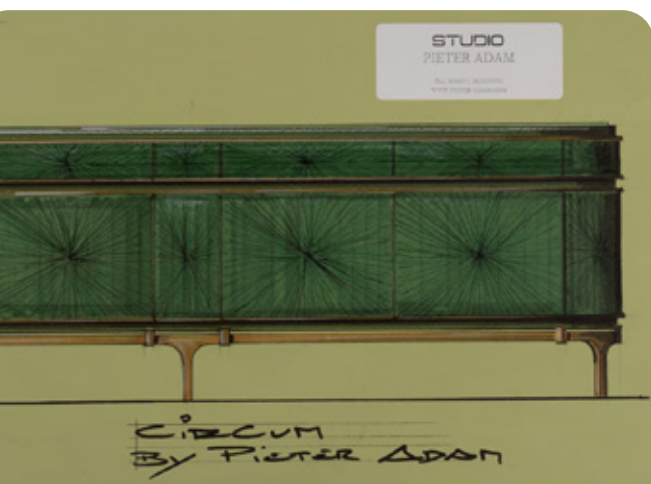
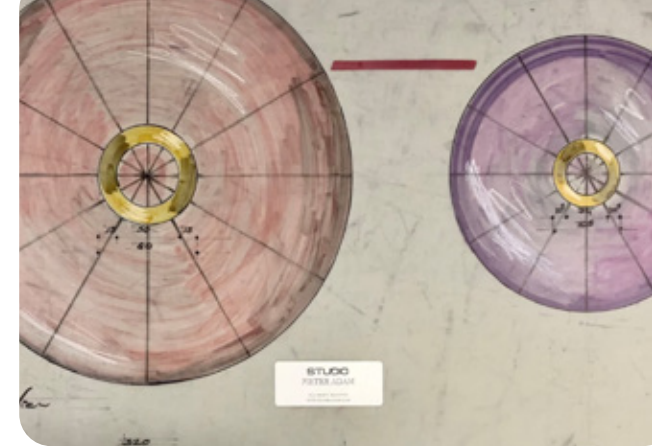
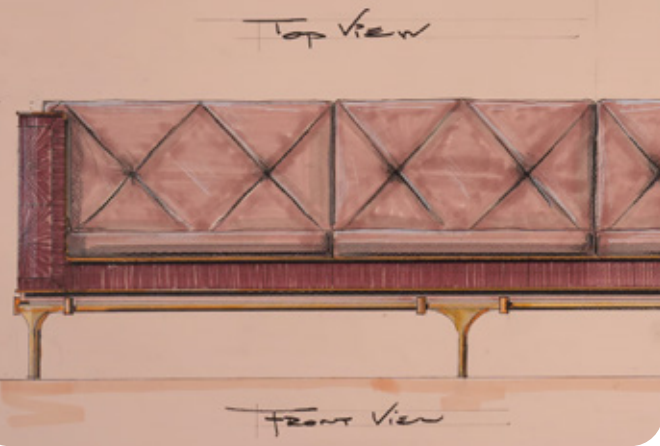



# MATERIAL LIBRARY

Welcome to Pieter Adam's Material Library, where creativity meets craftsmanship to bring your design visions to life. At Pieter Adam, we understand that every space is unique, and that's why we offer a wide range of materials and colours to customize a furniture piece exactly to your wishes and needs.

Our Material Library includes a curated selection of premium materials sourced from around the world, ensuring unparalleled quality and versatility in every piece. From luxurious woods to straw, sleek metals to opulent stones, the possibilities are endless.

Whether you're envisioning a bold statement piece or a subtle accent, our team of highly skilled artisans is dedicated to realizing your design dreams. With a lot of attention to detail and a commitment to excellence, we transform raw materials into exquisite furnishings.

We believe that furniture should not only enhance your space but also express your unique identity. That's why we empower you to choose the perfect combination of materials and colours to create a piece that is truly one-of-a-kind.

Discover the wide range of materials at the Material Library on our website, and let us bring your vision come to life.



Champagne



Natural



Natural dark

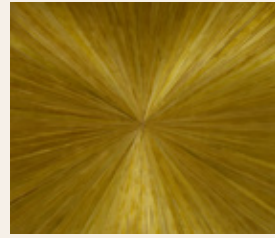

Light yellow



Gold



Apricot

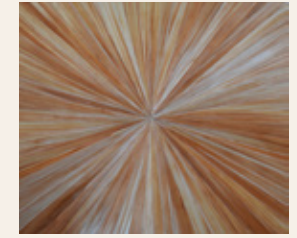

Rose

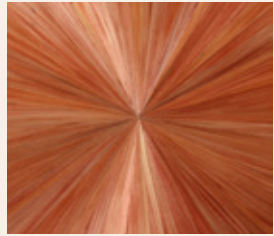

Blush Pink



Evening sun

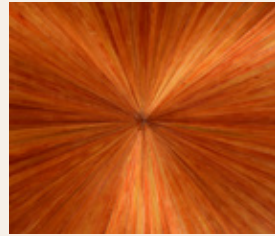

Dutch orange

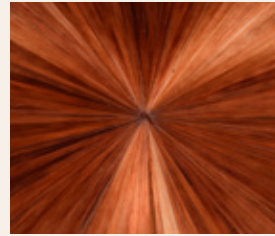

Chestnut Red

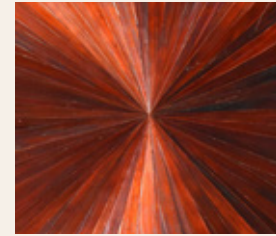

Dark red



Ruby Red



Emerald Green



Camouflage Green

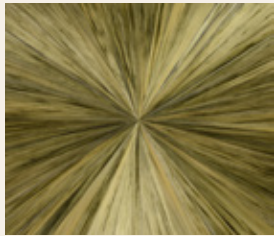

Worn Silver



Warm Gray



Fancy gray



Chestnut Brown



Forest Brown



Olive Brown

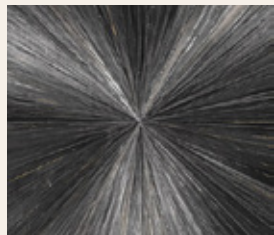

Black

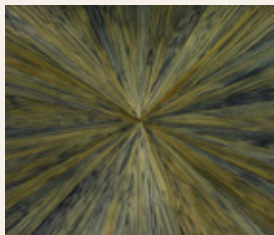

Green Blue

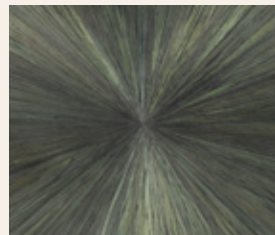

Ash Blue

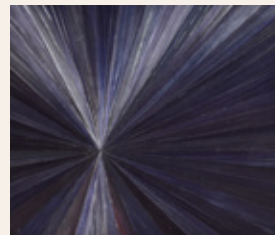

Iridescent Blue

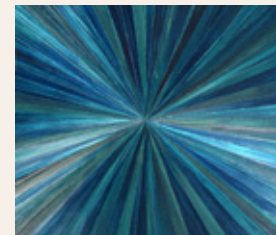

Neptune Blue

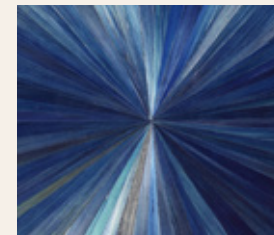

Sea Blue

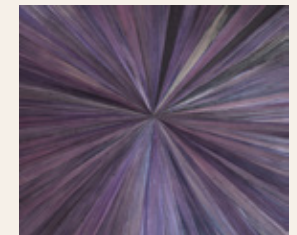

Lavender purple



Black square



Brown square



Black cube



Brown cube

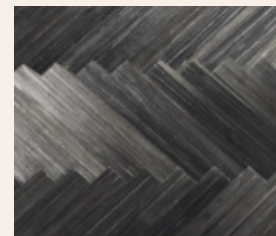

Black cross pattern

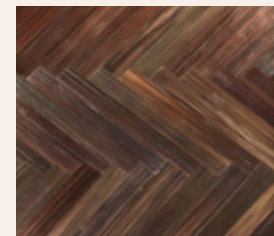

Brown cross pattern

# LEATHER

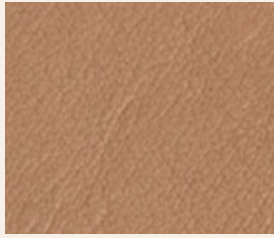

Rose



White Covered

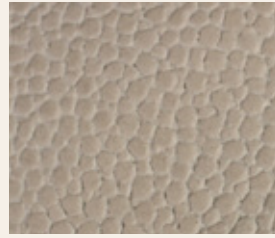

Pearl Covered



Cream Covered



Grey Covered



Grey Saddle



Coral Covered

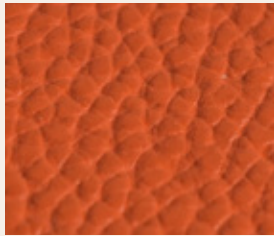

Orange Covered

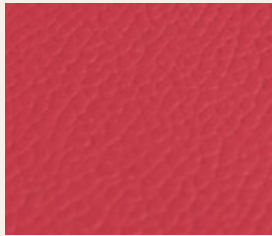

Pink Covered



Purple Covered

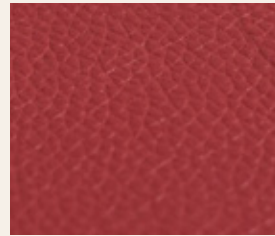

Cherry Covered

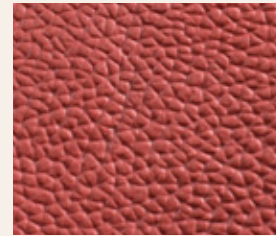

Red Covered



Rust Covered

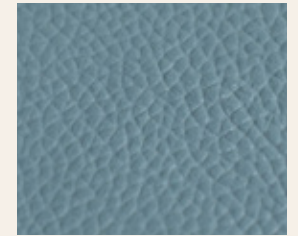

Sky Covered

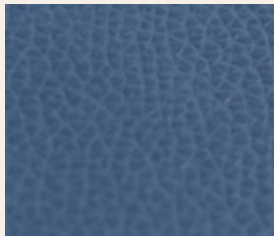

Blue Covered

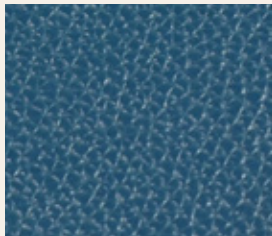

Naptune Blue

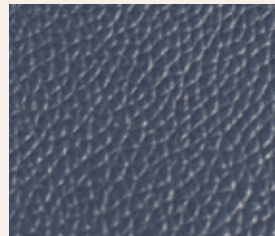

Ocean Covered

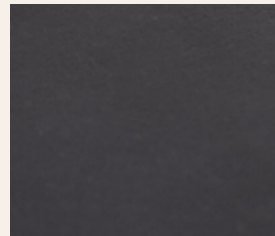

Navy Saddle

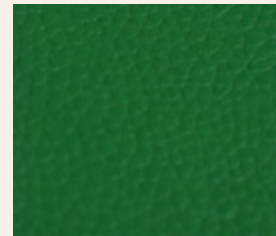

Green Covered

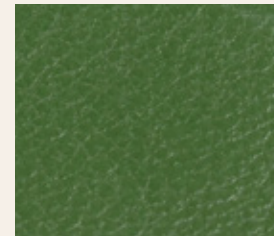

Olive Covered

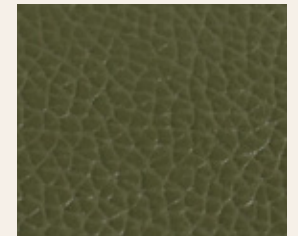

Sage Covered

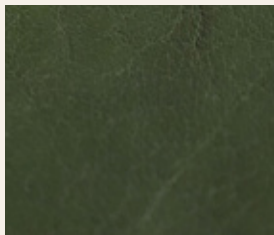

Olive Saddle

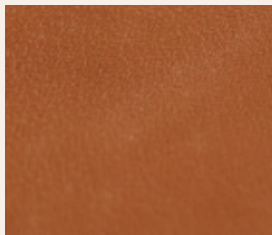

Tan Saddle

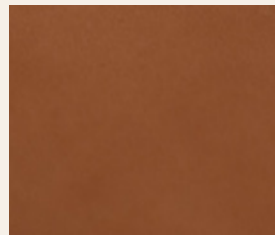

Camel Saddle



Camel Covered

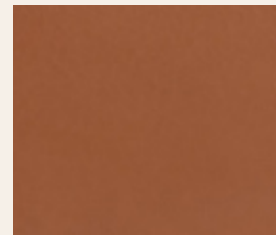

Brown Sanded

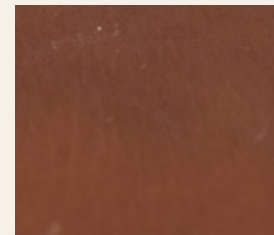

Bronze Saddle

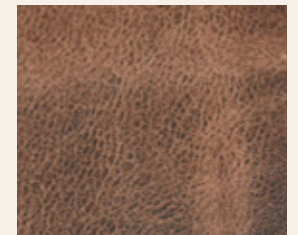

Bronze Sanded

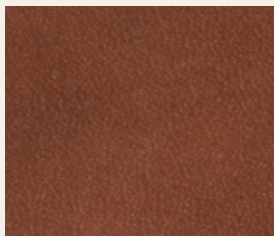

Cacao Saddle

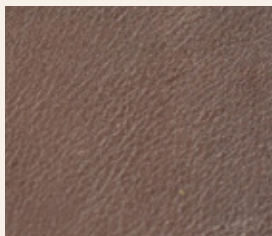

Brown Nubuck



Braid Black

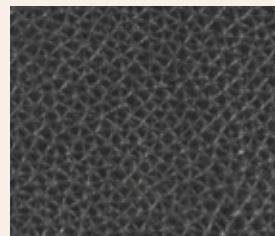

Black Covered

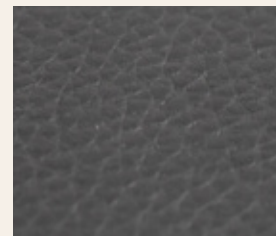

Black Covered

## ONYX

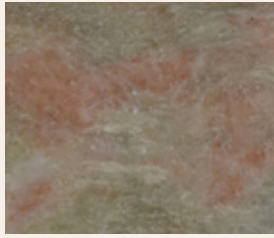

Pastel Green

## AGATE



White

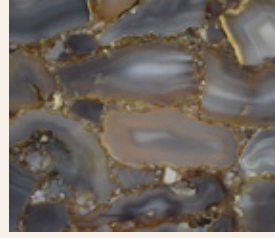

Grey

## BONE



Cross Pattern

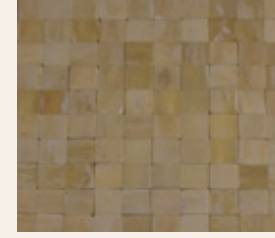

Block Inlay



Opposite Block Pattern

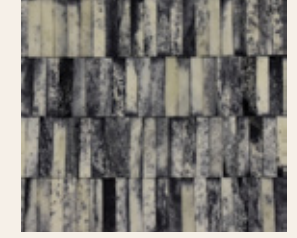

Stain

## RAFFIA

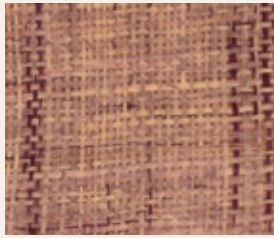

Blush

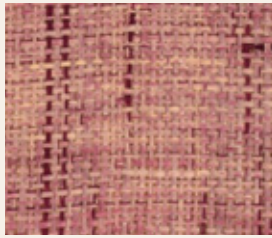

Ashes of Roses

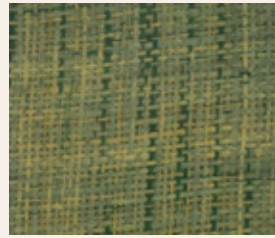

Olive Green

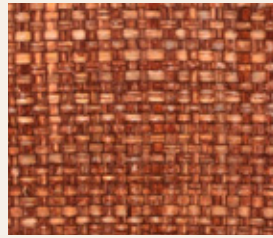

Bronze Red

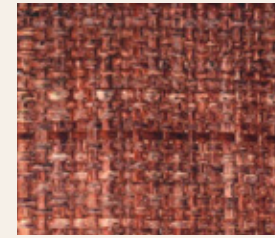

Etruscan Red

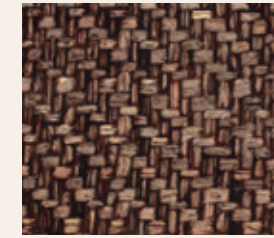

Warm Brown

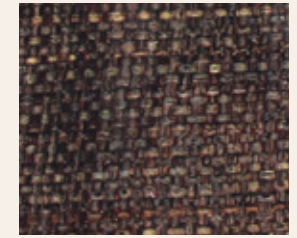

Deep Brown

## SELENITE



Natural Background



Gold Background

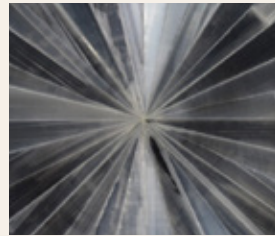

Black Background

### ONYX

Onyx is a colourful stone with a luxurious and exclusive appearance. It is special because of its crystal structure, but also because of the pattern, transparent appearance and colour gradient.

### AGATE

Agate is a gemstone known for its natural ground colours. A typical characteristic of agate is its ring-shaped appearance.

### SELENITE

Selenite is a near-gemstone variant of the mineral gypsum. The natural material has a special and luxurious appearance.

## BAMBOO

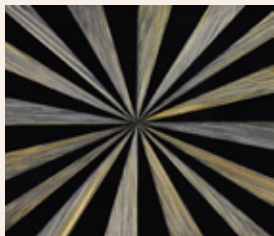

Sunshine Black



Sunshine Brown



Fantasy Geometric

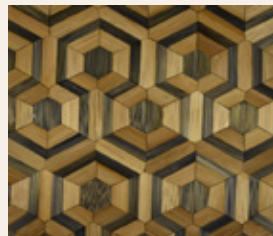

Hexagon

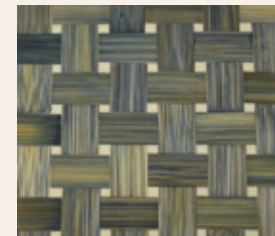

Braid

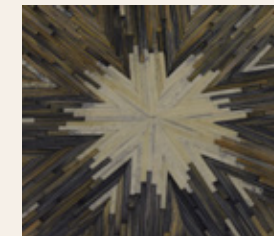

Snowflake

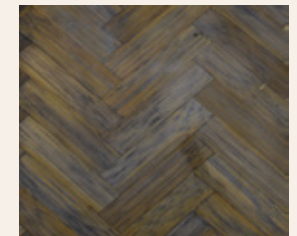

Cross Pattern



## VENEER

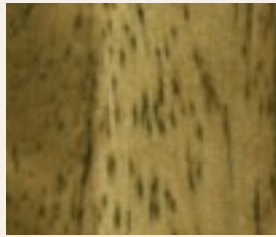

[Collection website>](#)

## CERAMIC

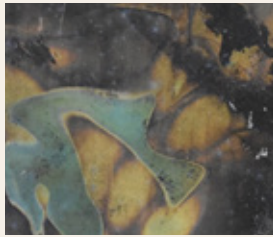

[Collection website>](#)

## MARBLE

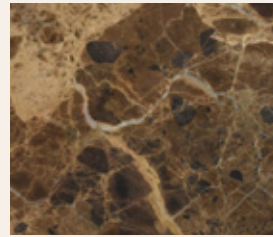

[Collection website>](#)

## MICA

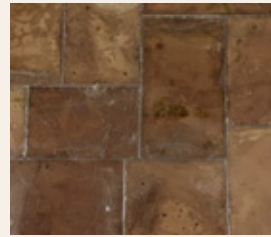

[Collection website>](#)

## PARCHMENT



[Collection website>](#)

## SAND STONE



[Collection website>](#)

## TRAUERTINE



[Collection website>](#)

## SPECIALS

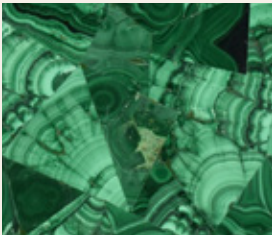

[Collection website>](#)

### VENEER

Veneer is a thin layer of wood, it could be used around a piece of furniture to give the piece of furniture a wooden look.

### CERAMIC

Ceramic is made from natural materials. Ceramic is a very strong and versatile material.

### MARBLE

Marble is one of the best-known types of natural stone. It has various colours, ranging from black, grey, yellow and white. The difference in structure and lighting makes marble very special. Its density also makes it very durable, marble is a good investment in your interior. Marble goes well with other natural materials and colours, such as copper, brass and wood.

### MICA

Mica is made from a crystallized mineral extracted and it has a shiny and metallic glow.

### PARCHMENT

Parchment is a kind of leather, which is light, flexible and strong.

### SAND STONE

Sand stone is a natural sedimentary rock consisting of compressed grains of sand and minerals. Sandstone comes in a variety of colours.

### TRAUERTINE

Travertine is a natural limestone that is recognizable by its veins and holes. The appearance of the natural stone provides a calm and luxurious look.

### SPECIALS

Special patterns and materials to use in your custom made piece.

INDEX

TABLES

TamTam table large  
Ø120 x H37 cm  
pagina 5



TamTam table medium  
Ø90 x H45cm  
pagina 7



TamTam table small  
Ø60 x H55 cm  
pagina 9



Collec(t)able rectangular  
coffee table large  
Ø60 x H55 cm  
pagina 11



Collec(t)able rectangular  
coffee table small  
90x 60 x H25 cm  
pagina 12



Collec(t)able end table  
70 x 70 x H45 cm  
pagina 14



Collec(t)able end table  
70 x 70 x H45 cm  
pagina 15



Collec(t)able  
high square pillar  
30 x 30 x H120 cm  
pagina 17



Collec(t)able sofa table  
40 x 55 x H70cm  
pagina 18



Collec(t)able sofa table  
with usb port  
Ø90 x H45cm  
pagina 19



Collec(t)able round side table  
Ø60 x H55 cm  
pagina 21



Collec(t)able round  
coffee table large  
Ø80 x H40 cm  
pagina 22



Collec(t)able round  
coffee table large  
Ø100 x H30 cm  
pagina 23



Collec(t)able high round pillar  
Ø35 x H120cm  
pagina 25



Circum end table  
80 x 80 x H42,5 cm  
pagina 44



Circum coffee table  
150 x 80 x H42,5 cm  
pagina 46

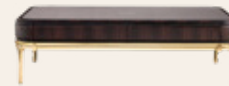

Baroctopus table  
ø100 x H52cm  
pagina 52



DRESSER -BOARDS

Circum dresser  
150 x 45 x H90 cm  
pagina 41



Circum lowboard  
206 x 55 x H65 cm  
pagina 42



Circum sideboard  
206 x 46 x H66,5 cm  
pagina 48



SOFA'S -CHAISE LONGUE

Collec(t)able sofa  
shelf service  
320 x 90 x H83 cm  
pagina 27



Collec(t)able chaise longue  
180 x 68 x H60 cm  
pagina 33



Collec(t)able sofa  
257,5 x 85 x H85 cm  
pagina 35



Circum sofa  
240 x 80 x H85 cm  
pagina 50



## INDEX

### CHAIRS

Collec(t)able chair shelf  
service righ  
120 x 85 x H85 cm  
pagina 29



Collec(t)able chair shelf  
service left  
120 x 85 x H85 cm  
pagina 31



Collec(t)able arm chair left  
68 x 68 x H60 cm  
pagina 36



### HOCKERS

Collec(t)able hocker  
85 x 65 x H40 cm  
pagina 38



Collec(t)able hocker  
85 x 65 x H40 cm  
pagina 39



### ACCESSORIES

Cocoon luxury box low  
Ø36 x H18 cm  
pagina 55



Cocoon luxury box high  
Ø36 x H29 cm  
pagina 57



Macaroon luxury box large  
Ø35 x H14 cm  
pagina 59



Macaroon luxury box small  
Ø25 x H14 cm  
pagina 60



Karma Chameleon  
W70 x D21 x H29 cm  
pagina 63



Volcano Candelabra  
42 x 42 x H52 cm  
pagina 66



### HANGING LAMPS

Sea Treasure hanging lamp  
70 x Ø38cm  
pagina 72



Curva Culta hanging lamp  
long big  
175 x 45cm  
pagina 79



Curva Culta hanging lamp  
long slim  
260 x 30cm  
pagina 80



Curva Culta hanging lamp  
short big  
117 x 45cm  
pagina 81



Curva Culta hanging lamp  
short slim  
25 x 25cm  
pagina 82



Melting Paradise hanging lamp  
80 x 90cm  
pagina 90



CarniForest hanging lamp  
42 x 55cm  
pagina 92



Twiggy hanging lamp small  
40 x 60cm  
pagina 118



Twiggy hanging lamp medium  
40 x 85cm  
pagina 119



Twiggy hanging lamp large  
40 x 140cm  
pagina 121



Twiggy hanging lamp oval XL  
30 x 200cm  
pagina 122



Rosedale hanging lamp round  
40 x 40cm  
pagina 138



Rosedale hanging lamp oval  
25 x 40cm  
pagina 139



Organic Atomic hanging lamp XL  
L185 x D70 x H75 cm  
pagina 145

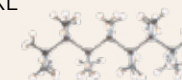

Organic Atomic hanging lamp  
L90 x D80 x H95 cm  
pagina 147



Organic Atomic lamp round XL  
Ø120 cm / Ø 80cm  
pagina 153



INDEX

FOLLOW-UP HANGING LAMPS

Pendant Bronx 4 shades  
on request x 65cm  
pagina 164



Pendant Bronx 8 shades  
on request x 145cm  
pagina 166



Melting Amsterdam chandelier  
60 x 60cm  
pagina 168



Melting Amsterdam  
chandelier XL  
55 x 100cm  
pagina 171



Melting Amsterdam  
hanging lamp XXL  
180 x 180cm  
pagina 173



Melting Fez hanging lamp  
130 x 40cm  
pagina 175



TABLE LAMPS

Sea Treasure table lamp  
77 x 37cm  
pagina 69



Curva Culta table lamp  
125 x 40cm  
pagina 76



Curva Culta table lamp  
with glass  
105 x 50cm  
pagina 77



Melting Paradise table lamp  
110 x 60cm  
pagina 86



CarniForest table lamp  
75 x 50cm  
pagina 94



Mysterious Bamboo  
table lamp  
88 x 33cm  
pagina 101



Melting Paris table-lamp vase  
88 x 40cm  
pagina 108



Melting Paris table-lamp  
83 x 27cm  
pagina 110



Melting Paris table-lamp  
83 x 27cm  
pagina 111



Melting Paris Sunday  
afternoon woman  
87 x 30cm  
pagina 115



Melting Paris Sunday  
afternoon men  
87 x 30cm  
pagina 116



Twiggy table lamp XL  
90 x 80cm  
pagina 127



Twiggy table lamp high  
110 x 40cm  
pagina 128



Rosedale table-lamp  
87 x 45cm  
pagina 133



Rosedale table-lamp  
87 x 45cm  
pagina 134



Rosedale table-lamp  
90 x 45cm  
pagina 135



Rosedale table-lamp big  
85 x 50cm  
pagina 137



Organic Atomic table lamp  
65 x 65cm  
pagina 151



Pavement table lamp big  
101 x 55cm  
pagina 156



Pavement table lamp slim  
103 x 37cm  
pagina 157



Bronx table-lamp  
74 x 38cm  
pagina 162



INDEX

FLOOR LAMPS

Melting Paradise floor lamp  
178 x 75cm  
pagina 87



Melting Paradise floor lamp XL  
217 x 90cm  
pagina 90



Mysterious Bamboo floor lamp S  
177 x 45cm  
pagina 103



Mysterious Bamboo floor lamp XL  
180 x 50cm  
pagina 105



Melting Paris floor-lamp  
152 x 32cm  
pagina 107



Twiggy floor lamp  
180 x 50cm  
pagina 130



Twiggy floor lamp XL  
189 x 140cm  
pagina 131



Bronx floor-lamp  
158 x 50cm  
pagina 163



WALL LAMPS

Sea Treasure wall lamp small  
70 x 31cm  
pagina 70



Sea Treasure wall lamp large - left  
117 x 35cm  
pagina 73



Sea Treasure wall lamp large - right  
117 x 35cm  
pagina 74



Curva Culta wall lamp slim  
3 x Ø24cm  
pagina 83



Curva Culta wall lamp big  
77 x Ø28cm  
pagina 84



CarniForest wall lamp  
56 x 45cm  
pagina 95



WornTorch 2l  
130 x 20cm  
pagina 98



WornTorch 1l  
100 x 12cm  
pagina 99



Melting Paris wall-torch long  
160 x 17,5cm  
pagina 112



Melting Paris wall-torch  
58 x 17,5cm  
pagina 113



Twiggy wall-sconce  
70 x 40cm  
pagina 124



Twiggy wall-sconce  
70 x 40cm  
pagina 125



Le Soleil wall lamp  
Ø30/40/60/80cm  
pagina 142



Organic Atomic wall sconce  
55 x 50 x 40cm  
pagina 149



Bronx wall-sconce  
52,5 x 12,5cm  
pagina 159



Bronx wall-sconce  
30 x 36cm  
pagina 160



Melting Amsterdam wall sconce  
35 x 50cm  
pagina 170



Melting Florence wall lantern medium  
65 x 25 x 35cm  
pagina 177



Melting Florence wall lantern large  
118 x 27 x 40cm  
pagina 178



Melting Florence wall lantern small  
55 x 24 x 14cm  
pagina 179



Our team is there for you!

“Should you have any questions or wish to bring a custom creation to life, feel free to reach out. We’d love to craft something uniquely yours.”

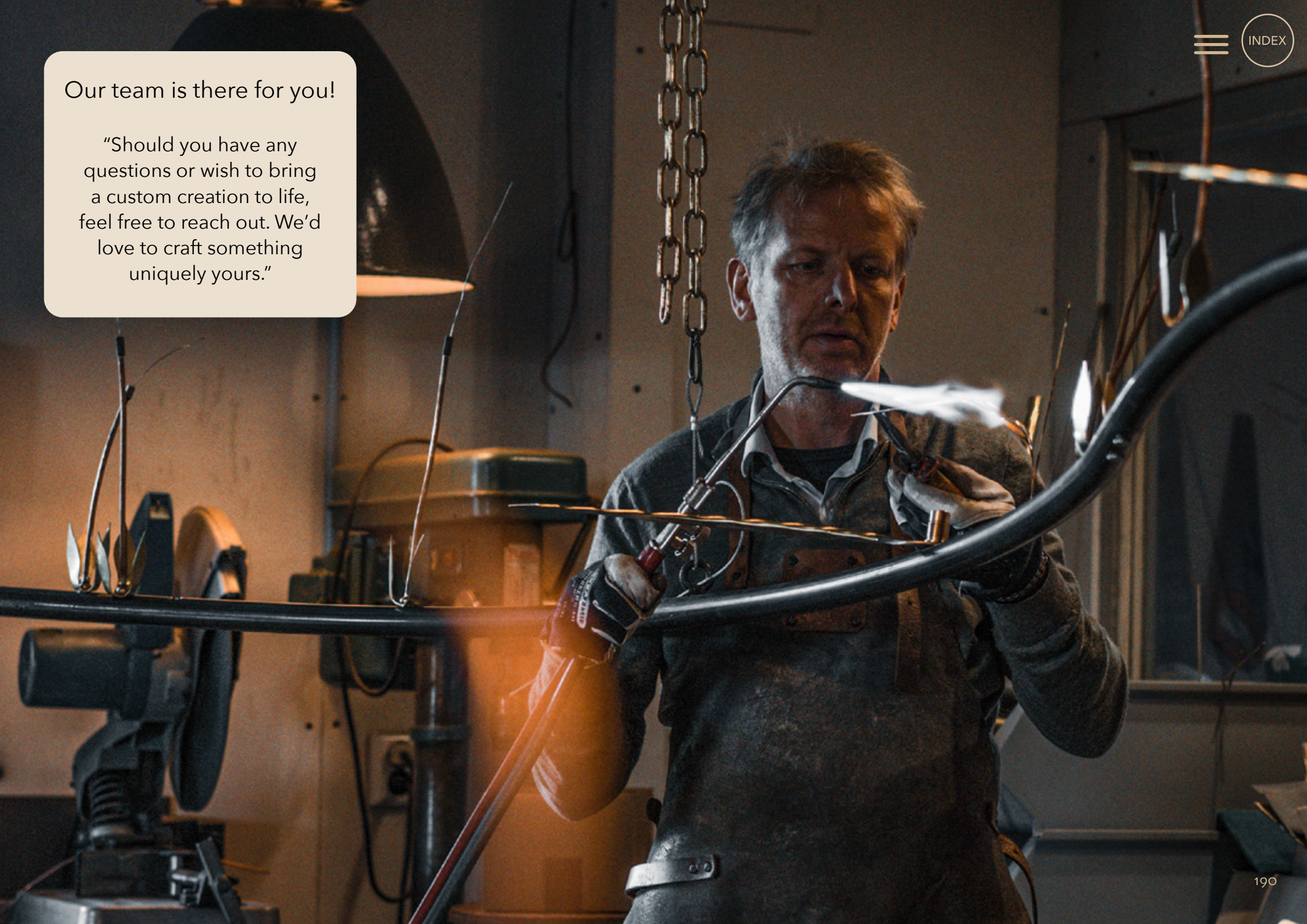



## PIETER ADAM STUDIO

An unique, creative space where everything is about atmosphere and lighting. Would you like to visit us? Our studio is exclusively open by appointment.

If you have any questions or requests, please do not hesitate to contact us.

We are always happy to assist!

For news (e.g. new collections, fairs/exhibitions etc.) visit our website or follow us on Instagram.

Distribution of Pieter Adam™ by:

Lumière

Lopikerweg oost 126

NL-3411 LZ LOPIKERKAPPEL - The Netherlands

[info@pieter-adam.com](mailto:info@pieter-adam.com)

[www.pieter-adam.com](http://www.pieter-adam.com)

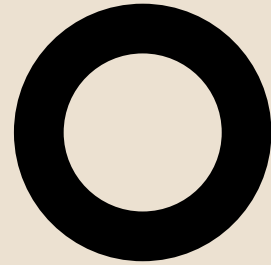

**PIETER ADAM**<sup>TM</sup>  
FURNITURE - LIGHTING - ACCESSORIES

[pieter-adam.com](http://pieter-adam.com)

Copyright © 2025 Pieter-Adam. All rights reserved.

Unless otherwise indicated, all models, materials, images, on these pages are copyrighted by Pieter-Adam.  
All rights reserved. No part of these pages, models, either text or image may be used.

Graphic Design by A.Graphique - [www.a-graphique.nl](http://www.a-graphique.nl)